



USER MANUAL

COMPUTRAC[®] MAX[®] 1000 MOISTURE ANALYZER OPERATION MANUAL

April 2003
Firmware Revision 4.2X

ARIZONA INSTRUMENT LLC
3375 N Delaware Street | Chandler, AZ 85225 USA
800.528.7411 | 602.470.1414 | f 602.281.1745

www.azic.com

Email:
General - azi@azic.com
International - intl@azic.com
Customer Service - support@azic.com

Computrac MAX 1000 User's Manual



PROPRIETARY RIGHTS NOTICE

The material in this manual contains valuable information developed by Arizona Instrument LLC for use with the Computrac line of moisture analyzers. No part of this manual may be reproduced or transmitted in any form or by any means, electronic, mechanical, or otherwise. This includes photocopying and recording or in connection with any information storage or retrieval system without the express written permission of Arizona Instrument LLC.

ALL RIGHTS RESERVED

© Copyright 2003 Arizona Instrument LLC

TABLE of CONTENTS

1.	WARNINGS AND SAFETY INFORMATION	5
2.	PACKING and SHIPPING INSTRUCTIONS	7
2.1.	MAX-1000 PACKING DIAGRAM	8
3.	INTRODUCTION	9
4.	INSTRUMENT DESCRIPTION.....	10
4.1.	Hardware.....	10
4.2.	Heating System	10
5.	INSTRUMENT SETUP	11
5.1.	Instrument Location	11
5.2.	Interior of Test Chamber.....	12
5.3.	AC Power Connection	13
5.4.	Controls.....	14
5.5.	Calibrate Balance - 20 gram weight required.....	15
5.6.	Weight Test - three and five gram weights required.....	17
5.7.	Connecting Nitrogen Purge Kit AZI P/N Y990-0046.....	18
5.8.	Connecting a Printer	20
5.9.	Connecting a Computer	22
5.10.	Test Procedure	23
5.11.	Test Data Output.....	24
6.	MENU SYSTEM: Instrument Configuration And Operation	25
6.1.	MAIN MENU	26
6.2.	Memory Start Menu.....	27
➤	Add/Edit Memory Start	27
⇒	Sample Name	27
⇒	Temperatures.....	27
	Test Temperature	27
	Test Histart Temperature	28
	Idle Temperature.....	28
	Start Temp Control	28
⇒	Ending Criteria	29
	End Test on Prediction.....	29
	End Test on Rate.....	29
⇒	Sample Size Options	30
	Sample Size	30
	Sample Window.....	30
	Inside Limits and Outside Limits.....	30
⇒	Tare Options.....	31
	Pan Tare Options	31
	Sample Tare Option.....	32
	Special Options.....	33
⇒	Result Display Options	33
➤	Reorder Memory Start.....	33
➤	Delete Memory Start	33
➤	Print Memory Start.....	34
6.3.	STORED DATA (Not available on 21 CFR, Part II compliant instruments).....	35
➤	View Last Test Data	35
➤	Print Last Test Data.....	35
6.4.	CALIBRATION MENU.....	35
➤	Balance Calibration	35
➤	PRINT BALANCE CAL REPORT	35

6.5.	SETUP MENU.....	36
➤	Printer Setup	36
➤	Report Setup	36
⇒	Report Control Options	36
⇒	Report Items to Print	37
⇒	Add/Edit Company Name	37
➤	Clock Setup.....	37
➤	Data Format Setup	38
⇒	EC Display	38
⇒	Lot Number	38
➤	Access Key Setup	38
7.	MEMRY - Memory Start Selections.....	40
8.	PARAM: Temporarily Changing Test Parameters	40
9.	MISCELLANEOUS MESSAGES	41
9.1.	Control Program Version Number	41
9.2.	Diagnostic Failure Messages.....	41
10.	PERFORMANCE ENHANCEMENT	42
10.1.	Selection of Test Temperature	44
10.2.	Selection of Ending Criteria.....	45
10.3.	Preparing Granular and Powdery Samples.....	45
10.4.	Preparing and Testing Liquid Samples	46
10.5.	Selecting the Optimum Sample Size.....	46
11.	PERFORMANCE VERIFICATION	47
11.1.	The Weight Test.....	47
11.2.	The Precision Weight Test.....	47
11.3.	Sodium Tartrate Test.....	48
11.4.	Precision Tartrate Test	49
11.5.	Retained Samples.....	50
12.	ROUTINE MAINTENANCE	51
12.1.	Chamber Interior	51
12.2.	Heater Cleaning.....	51
12.3.	Sample Pan Support	52
13.	TROUBLE MESSAGES	53
14.	TROUBLE DIAGNOSIS	54
15.	SPECIFICATIONS.....	57
16.	ACCESSORIES & MAINTENANCE PARTS.....	59
17.	WARRANTY	60
18.	MAINTENANCE CONTRACT	61

1. WARNINGS AND SAFETY INFORMATION

The MAX 1000 Moisture Analyzer complies with the Underwriter Laboratories Inc. standards and European Council Directives for Electrical Equipment for Laboratory Use, electromagnetic compatibility, and the stipulated safety requirements. However, improper use or handling of instrument can result in damage to equipment and/or injury to personnel.

The MAX 1000 Moisture Analyzer is identified as Equipment Class I, Pollution Degree 2, and Installation Category II.

Read this manual thoroughly before using your moisture analyzer to prevent damage to the equipment. Keep these instructions in a safe place. An up-to-date electronic copy of this manual can be found at the Arizona Instrument (AZI) web site at <http://www.azic.com>.

The following instructions will help to ensure safe and trouble-free operation of your moisture analyzer.

- Use the moisture analyzer only for performing moisture analysis of samples. Any improper use of the analyzer can endanger persons and may result in damage to the analyzer or other material assets.
- Do not use this moisture analyzer in a hazardous area/location; operate it only under the ambient conditions specified in these instructions.
- Although the moisture analyzer is simple to operate and is very user friendly, it should only be operated by qualified persons who are familiar with the properties of the sample being analyzed.
- Ensure, before getting started, that the voltage rating printed on the manufacturer's label is identical to your local line voltage (see the section beginning on page 13).
- The MAX 1000 Moisture Analyzer is provided with a power cord that has a protective grounding conductor. Do not operate the unit without the supplied three-wire power cord or an identical, recognized equivalent that meets all applicable standards.
- AZI does not recommend the use of an extension cord. However, if one must be used, use an extension cord that meets all applicable standards and has a protective grounding conductor.
- Do not remove the protective grounding wire from the power supply circuit.
- With the power switch off, power is still applied to the power entry module. Disconnect the power cord from the instrument to ensure complete power removal.
- Position the power cable so that it cannot touch any hot areas of the moisture analyzer.

- Use only AZI-supplied accessories and options with the MAX 1000 Moisture Analyzer or check with AZI before using any third party accessories, such as printers and analytical balances, to verify compatibility.
- If there is visible damage to the MAX 1000 Moisture Analyzer or its power cord, unplug and isolate the unit first and then call AZI customer service at 1800-528-7411 or 1-602-470-1414.
- Do not open the housing of the MAX 1000 Moisture Analyzer. There are no user serviceable parts or adjustments inside the unit. Any maintenance inside the unit is to be performed by factory-trained technicians only. Any unauthorized inspection and/or maintenance of the MAX 1000 Moisture Analyzer will void the warranty.

Prevent excess heat build-up around the analyzer

- When setting up the MAX 1000, leave enough space to prevent heat from building up and to keep your analyzer from over-heating. Leave 20 cm (about 8 inches) around the moisture analyzer and 1 meter (about 3 ft.) above the unit.
- Do not put any flammable substances on, under or around the moisture analyzer.
- Use extreme care when handling the used sample pan when removing it from the unit. Although the pans cool rapidly, they are still very hot when the lid is first opened after a test.

HAZARDS FOR PERSONS OR EQUIPMENT POSED BY USING SPECIFIC SAMPLES:

Flammables; explosives; substances that contain flammables, explosives, solvents; and/or substances that release flammable or explosive gases or vapors during the drying process.

- If flammable or explosive liquids are tested, the gases escaping from the unit are still dangerous when they are exposed to the atmosphere. Fume hoods may offer partial protection but the potential danger will still be present. The user shall be liable and responsible for any damage that arises in connection with the MAX 1000 Moisture Analyzer and potentially harmful substances.
- Substances containing toxic, caustic or corrosive substances may be analyzed with the unit in an appropriate fume hood only. The fume hood must keep the work area below the lower toxic limit established by appropriate standards.

- Substances that release caustic vapor such as acids should be analyzed in the smallest sample size possible to still achieve satisfactory results. If vapors condense on the MAX 1000 Moisture Analyzer's housing parts, stop the testing, wipe the surface clean with a suitable neutralizer and place the unit in a fume hood capable of removing the vapors. The instrument is composed of powder coated aluminum, anodized aluminum, and some brass fittings. Check for compatibility of substances to be tested before inserting them into the instrument.
- The user has the responsibility for carrying out appropriate decontamination if hazardous material is spilt on or inside the MAX 1000 Moisture Analyzer.

CLEANING

- Clean the MAX 1000 Moisture Analyzer according to the cleaning instructions only. Use of strong detergents and "oven cleaners" will damage the case and heater housing.
- Before using any cleaning or decontamination method, except those recommended by Arizona Instrument, check with AZI customer service at 1-602-470-1414 or 1-800-528-7411, to ensure that the proposed method will not damage the equipment.
- The outside housing of the MAX 1000 Moisture Analyzer should be cleaned with a mild household detergent such as 409® and a soft, lint-free cloth. Paper towels should never be used, as they will scratch the instrument's finish and the clear lens over the display. If methods that are more stringent are required, call AZI customer service at 1-602-470-1414 or 1-800-528-7411 for recommendations.
- Every precaution has been taken to prevent contaminants from entering the unit. However, if liquids or powders do enter the case, call AZI customer service at 1-602-470-1414 or 1-800-528-7411 for recommendations.

The user shall be liable and responsible for any damage that arises in connection with the use of this moisture analyzer.

ENVIRONMENTAL CONDITIONS

Storage and Shipping

- Temperature should be between 0 °C to +40 °C (+32 °F to +104 °F).
- Relative Humidity should be between 10% and 80%.

OPERATIONAL CONDITIONS – INDOOR USE.

- Optimum results will be achieved when the unit is set on a smooth, level, non-vibrating surface in a non-condensing, non-explosive environment of 0-40° C @ 50% relative humidity and 0-31° C @ 80% relative humidity.
- Do not expose the moisture analyzer unnecessarily to extreme temperatures, moisture, shocks, blows or vibration.

UNPACKING THE MOISTURE ANALYZER

- After unpacking the moisture analyzer, check it immediately for any visible damage resulting from rough handling during shipment.
- Save the box and all parts of the packaging to use when returning your moisture analyzer for calibration. Only the original packaging provides the AZI-recommended protection for shipment. Before packing your moisture analyzer for shipment, unplug all connected cables to prevent damage during transit.

WARNING SYMBOLS



- Protective Ground

Identifies the connection on the Chassis and Power Inlet Module for connection of the safety ground (green/yellow) wire.



- Warning

Information or procedure that must be observed.



- Electrical Shock Hazard.

Observe all steps of the procedure to prevent electrical shock.



- Warning, Hot surface or area of possible severe burns.

Use listed precautions when opening the oven lid and handling samples to prevent injury.

2. PACKING AND SHIPPING INSTRUCTIONS

IMPORTANT

Movement, handling, and packaging of the instrument must be done with EXTREME CARE to avoid permanent, expensive internal damage. The MAX 1000 uses a delicate and very sensitive electronic force balance to measure small weights and weight losses. The balance is capable of measuring weight to a resolution of 0.100 milligram, over a sample weight range from 150 milligrams to 40 grams. Careful handling is necessary to prevent damage to the balance. With proper care, the instrument will provide years of dependable service.

UNPACKING

Unpack the instrument carefully and set it down gently. Select a place where it will be safe from bumping, jarring, excessive air currents, and vibration.

Retain all packaging materials for any future shipment of the instrument. If the instrument is returned to (AZI) for any reason, it must be placed in the original packaging materials which have been tested and proven to be effective protection during shipment. See page 8.

REPACKAGING FOR SHIPMENT

- Call AZI Customer Service At 1-800-528-7411 or 1-602-470-1414 for Return Material Authorization (RMA) information prior to returning a unit.
- For all shipments, boxes and packing materials are available from AZI.
- Pack the MAX 1000 in a Computrac MAX 1000 shipping container, using the packing diagram on the box as a guide.

**AZI WILL NOT BE RESPONSIBLE FOR SHIPPING DAMAGE.
IF YOU RETURN THE INSTRUMENT IMPROPERLY PACKAGED OR SHIPPED YOU
SHOULD INSURE IT FOR FULL REPLACEMENT VALUE.**

2.1. MAX-1000 PACKING DIAGRAM

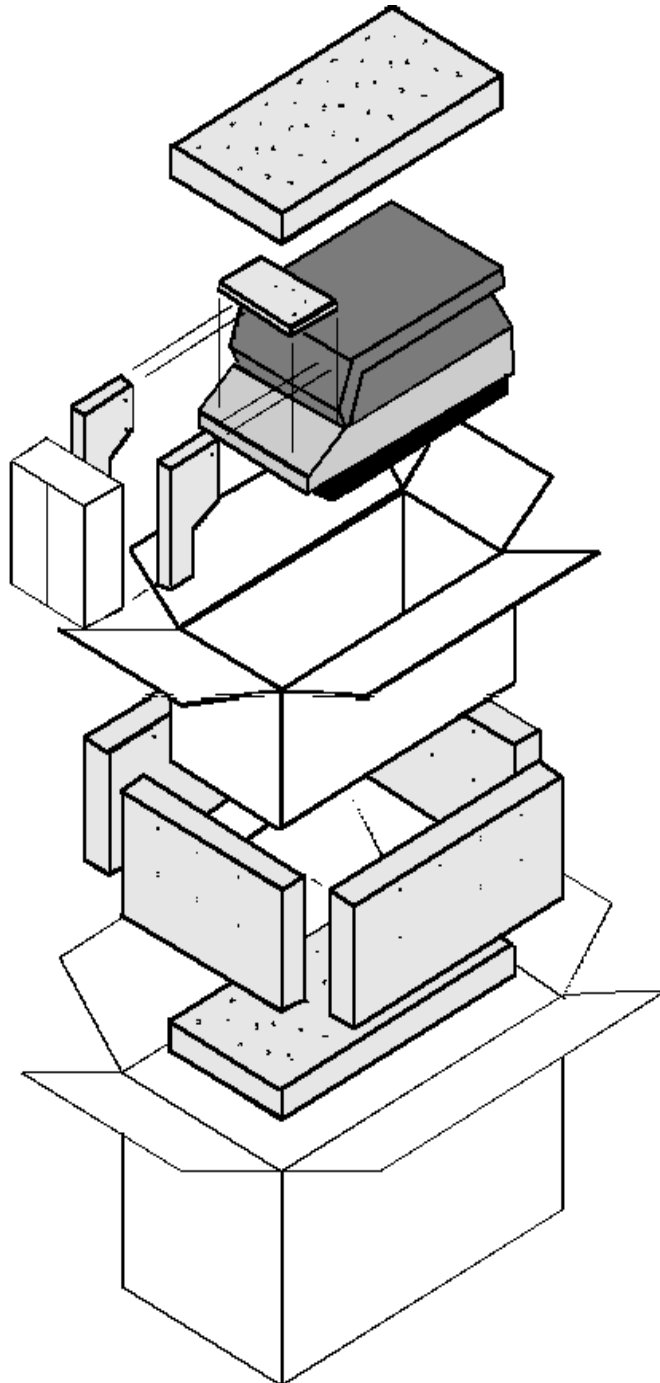

3. INTRODUCTION

The Computrac MAX 1000, manufactured by Arizona Instrument LLC of Tempe Arizona, is a high performance programmable moisture analyzer. It uses the proven loss-on-drying method to detect the volatile content of a sample of test material. The instrument may be programmed to use Arizona Instrument's pioneering prediction method of automatically ending a test to provide accurate results in the shortest possible time.

Typically, the instrument result is precise to better than 2.0% Coefficient of Variation (CV) from 0.100% - 100%

The MAX 1000 will test at temperatures from 25 °C to 225 °C set at increments of one degree. The advanced heat control program brings the sample up to temperature in less than three minutes. Depending on the rate of volatilization of the sample moisture, test results are available in as little as two minutes, twice as fast as older instruments of this type.

The instrument is programmable through the easy-to-use front panel menu system. For plant control purposes, the programming features can be placed under access code control, preventing unwanted changes to operating parameters. Advanced computer circuitry enables the instrument to be programmed with test parameters for 5 different materials in addition to the two factory set test parameters, Weight Test and Tartrate, and one rapid change set for parameter development.

Test data can:

- Be sent directly to a personal computer, and/or
- Be printed on many graphics-capable printers

4. INSTRUMENT DESCRIPTION

4.1. Hardware

The MAX 1000 consists of a small convection air oven, a weighing mechanism with a resolution of 0.1 milligrams and a full-scale range of 40 grams, and a backlit, graphic Liquid Crystal Display (LCD). A microprocessor controls the test process, data handling, communications, and performs all necessary calculations. A small fan in the lower chassis maintains the electronics at a stable, low temperature. Connectors for a printer and serial communications devices are provided at the back. The power input module can be set for either 100-120 volts or 220-240 volts, (see page 13).

The MAX 1000 is designed to remain powered up at all times. When it is not in use, keep the lid down. The light behind the LCD will turn off after a period of inactivity to conserve energy. The display is visible but appears very dim. Press any key to restore the backlight to illuminate the LCD.

4.2. Heating System

The sample heating system is designed to remove volatile components from the sample as quickly as possible, while maintaining accurate temperature control to prevent sample degradation. Oven temperature is measured with a Resistance Temperature Device (RTD), mounted in a rugged metal tube to prevent damage and dislocation. Temperature control accuracy is within one degree of the set value after equilibrium is reached. The 700-watt heater reaches equilibrium in 90 to 180 seconds, depending on the difference between the starting and setpoint temperatures. Closed loop feedback control assures a constant temperature even if power line voltage varies during the test. The heating system is automatically turned off when the test is completed. **Open the lid to speed cooling before performing the next test, if needed.**

5. INSTRUMENT SETUP

Call Arizona Instrument (AZI) customer service or your technical sales representative at 1-800-528-7411 or 1-602-470-1414 if you have any questions about the following instructions. You may also contact customer service by e-mail at support@azic.com. Updated revisions to this manual are available at the AZI web site. Log onto <http://www.azic.com>, click on PRODUCTS, click on COMPUTRAC, and page down to the list of available manuals.

For those familiar with moisture analysis instruments, the MAX 1000 should be simple to operate. If you are unfamiliar with this technology, **please read all of the sections in this manual before attempting your first analysis.**

5.1. Instrument Location

- Select a location for the instrument that is:
 - Firm and level,
 - Free from vibration that will affect the balance measurements,
 - Close to an isolated power outlet that will provide dedicated electrical power, and
 - Away from the direct flow of a fan or heating/air-conditioning outlet that might produce force on the balance.

Please save the shipping box and all packaging materials for future use.

- Carefully unpack the instrument and locate the following items:

Part Name	AZI Part Number		
MAX 1000	MAX-1000	MAX-1000-220V	
Accessory Kit	Y990-0157		
Line Cord (Varies with area)	USA/Canada	England	Europe
	200-0002	200-0003	200-0008
Sample Pans:	Waffle	990-0008	
Test Weights:	3 grams	690-0003	
	5 grams	690-0004	
	20 grams	690-0007	
Tweezers	690-0012		
User's Manual	700-0036		
Optional Accessories			
Printer Kit	Y990-0098		
RS-232 Cable - null modem for computer interface	6000-1044		
Temperature Calibration Kit	300-0114		
Sample Pans:	Flat	990-0010	
Filter Paper	990-0003		
Shipping Container	751-0008		
Nitrogen Purge Kit	Y990-0046		

5.2. Interior of Test Chamber

- Open the lid by lifting the handle just above the display.
- Remove the yellow tape, pan support and packing foam.
- Save the foam so that it can be taped in place when the instrument is returned to the factory for annual calibration.
- Install the pan support gently but firmly into the instrument.



CAUTION - Do not, at any time, attempt to spin the pan support as it may result in damage to the force balance. Avoid excess pressure from the top or sides, which can damage the force balance.



NOTE: The Outside Shroud Gasket is not used in all applications and may not be included with your instrument.

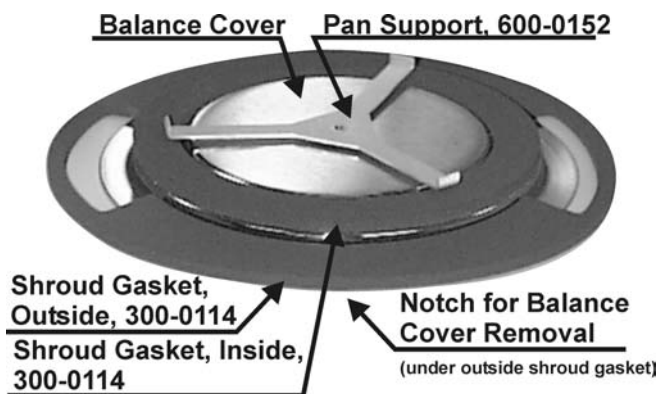

Check the clearance between the pan support arms and the heat shield by observing the space between the arms and the inside shroud gasket. The clearance should be about one millimeter or about the thickness of an American dime. If the clearance is considerably different than one millimeter or the pan support appears to be crooked, call AZI customer service or your technical sales representative at 1-800-528-7411 or 1-602-470-1414.



Ensure the AC power receptacle is set for the correct voltage (110 or 230 VAC). The MAX 1000 will draw up to eight (8) amps. Ensure the instrument is provided with its own **DEDICATED and GROUNDED** electrical power outlet. Do not put it on a circuit with motors, blenders, heaters, coolers, grinders, or other high-current electrical devices.



5.3. AC Power Connection

The MAX 1000 can be used with either 100-120 or 220-240 VAC. Check the setting on the fuse holder, located at the rear of the instrument, for correct voltage (100-120 or 220-240 volts) from your power receptacle.

To change from 110 to 220VAC, or from 220 to 110VAC:

- Remove the tab in the fuse holder and reverse the small card inside.
- Change the fuse:
 - A unit operating from 100-120 VAC should have two each, eight (8) amp slow blow fuses, (AZI P/N 190-1001).
 - A unit operating from 200-240 VAC unit should have two each, four (4) amp slow blow fuses, (AZI P/N 190-1002).
- Slide the card in the center of the fuse holder out, turn it around, and slide it back in so that the correct voltage shows through the window of the fuse holder.
- Ensure the power switch, located next to the fuse holder, is in the off (O) position.
- Remove the power cord from the packing material and insert the rectangular end into the power receptacle, located on the other side of the fuse holder.



The power source outlet used by the MAX 1000 **MUST BE GROUNDED**. (If you are not sure if the socket is grounded, check with your plant electrician before proceeding). **The MAX 1000 will appear to function correctly even if the socket is not grounded, but there is a danger of possible electrocution! If grounded outlets are not available, consider using a ground fault interrupter to protect personnel against electrical shock.**



- Plug the line cord into its dedicated electrical power outlet. Line noise on the power lines may affect accuracy. A dedicated AC power line or an isolation transformer for the MAX 1000 may be beneficial in eliminating this noise.
- The MAX 1000 is designed to remain powered up at all times. Turn the instrument on by pressing the switch on the back of the analyzer above the power receptacle and the opening screen will appear. The firmware version number is in the bottom center of the display.

MAX-1000
Copyright 2002
Arizona Instrument
Version 4.2X

- Adjust the contrast controls on the analyzer's front panel as necessary to view the screen display.
- Before beginning any test, allow the instrument to warm up for 30 minutes.



5.4. Controls

- The front panel controls consist of two arrow keys at the left used to adjust the display [CONTRAST]; five small keys below the display labeled [◀], [▶], [▲], and [▼]; and a large [START] key at the right side of the panel.

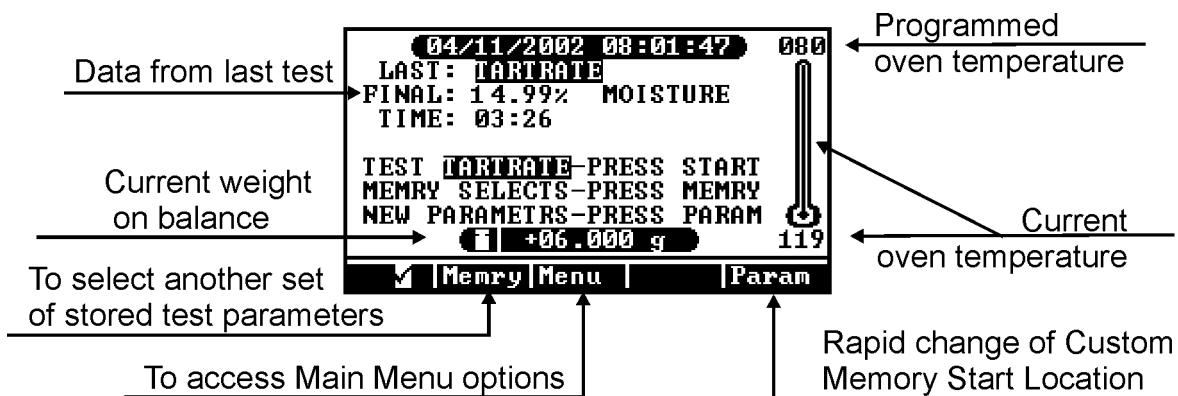

- Start moisture tests by pressing the [START] Key.
 - If all system parameters have been selected for the selected test, no other keystrokes are required to complete most tests.
 - Follow the steps as they appear on the screen, and wait for the audible signal at the end of the test.



- The four arrow keys, [◀], [▶], [▲], [▼], are used to navigate through the menu system, and to respond to prompts on the screen. The function of the key appears above the key. As an example, the name [Param] above the [▼] changes to [Quit] during tests. This indicates that the test will be terminated and computations canceled when the key is pressed.

- When using the menu system to change a numeric value, such as a name or temperature:
 - Use [◀], and [▶], to select the character position to be changed.
 - Use the [▲], and [▼], to increase or decrease the character in the selected position.

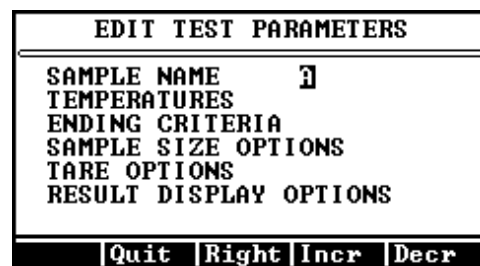

- The alphanumeric digit/place can contain one of 12 symbols in addition to the alphabet and the numbers 0 to 9. Pressing [Incr] starts at "A" and continues through the alphabet, the symbols, then the numbers. Pressing [Decr] first starts at the numbers, then symbols and finally, the alphabet.
- When the changes are completed, move the cursor off the end of the entry, either to the left or right, to [Quit] the edit mode.
- Use the [▲], to accept or the [▼], to cancel the changes made.

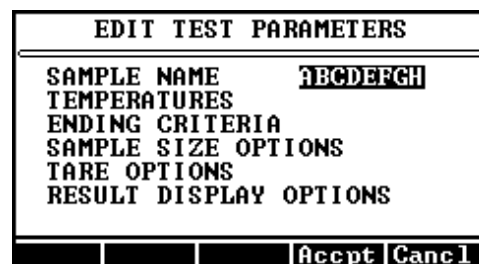
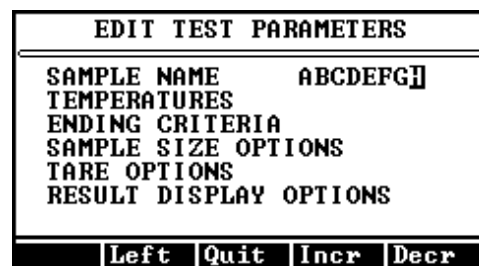

NOTE: Prompts to remind the user of key functions are always displayed above the keys and change as necessary throughout the menu system.

5.5. Calibrate Balance - 20 gram weight required

- The balance should be calibrated:
 - Immediately after initial setup,
 - Whenever the instrument is moved,
 - Whenever a problem is suspected, or
 - As your Quality Policy dictates.
- The screen will prompt you to have a clean, dry sample pan, and a 20-gram calibration mass available before beginning the calibration process.

NOTE: Best results are obtained if the MAX 1000 has been turned on for 20 to 30 minutes, depending on ambient temperature, and the chamber temperature stabilized at 80°C for five minutes prior to calibration. A vibration-free table will speed the calibration process since the balance will stabilize more quickly if it is not subject to vibration.

- Preheat the chamber to 80°C:
 - Ensure the lid is closed and press the [Memry] key to display a list of the memory starts.

- Highlight memory start 01 TARTRATE and press the [START] key.
- Press [Quit]. The unit will heat the chamber to the 80°C programmed idle temperature.
- **Wait five minutes.**
- Press [Memry] and highlight 00-WEIGHT.
- Press [START].
- Press [Quit].

- Press [Menu].
- Select the CALIBRATION MENU.
- Highlight BALANCE CALIBRATION and press [Select].
- Ensure CALIBRATE BALANCE is highlighted and press [Select].
- Press [GO] to begin the calibration procedure. Follow the prompts to complete the calibration.
 - The first prompt is “OPEN THE LID.”
 - After placing a clean pan on the balance and closing the door, the screen will indicate “TARING PAN – PLEASE WAIT.”
 - As soon as the tare is finished, the next “OPEN THE LID” prompt will appear.
 - As the lid is opened, the screen prompt asks that a 20-gram weight be carefully placed in the center of the pan and the lid be closed.



Avoid excess pressure on the scale. Use the tweezers to gently place the weight on the pan.



- With the 20-gram weight in place, gently close the lid.
- As the MAX 1000 calibrates itself, the screen displays the
- “CALIBRATING BALANCE” message.
- For best results, the unit should not be moved, jarred, or otherwise disturbed in any way during this calibration time.
- When the calibration is complete, the screen displays the results.
 - If the result is $+20.000 \pm 0.015$ g, the calibration was successful and the MAX 1000 is ready for use.
 - If the weight result is out of this range, the calibration was unsuccessful. Rerun the calibration.
 - If the calibration fails again, contact AZI customer service at 1-800-528-7411 or 602-470-1414.
- Press [Esc] four (4) times to return to the Main Test Screen.

5.6. Weight Test - three and five gram weights required

To ensure proper calibration and become familiar with the instrument, run a weight test. This test simulates moisture content by the removal of one of two known weights.

- Ensure a clean and dry, empty sample pan is placed on the pan support.
- From the Main Test Screen, press the [**Memory**] key.
- If the highlight bar is not already there, highlight “00 ID: WEIGHT” and press [**START**].
- When the “OPEN THE LID” prompt appears on the screen, open the lid and carefully place both a 5-gram and a 3-gram weight near the center of the sample pan.
- Close the lid.
- After the testing screen is displayed, gently open the lid and carefully remove the 3-gram weight.
- Wait for the end of the test.
- If this is the first test of the day, discard the results of this test for stability reasons.
- Record the final result. The value should fall between 37.480% and 37.520%.

5.7. Connecting Nitrogen Purge Kit AZI P/N Y990-0046



CAUTION:
Use of nitrogen or other inert carrier gas does not create
an explosion-proof system.



Some applications may require the use of a nitrogen purge to remove volatiles from the chamber.

- In addition to the Nitrogen Purge Kit, the following materials will be required for the nitrogen purge setup:
 - Nitrogen source/cylinder or other supplied inert gas source
 - Two-stage regulator capable of regulating pressure to 5 psi
 - For cylinder applications: Multi-stage Gas Regulator for Compressed Air Cylinder, VWR #55850-150, # 55850-155 or equivalent, or Matheson Gas Products Brass Dual Stage Regulator, model 8L or equivalent
 - For supplied gas sources: Matheson Gas Products Model 3471 Single Stage Line Regulator or equivalent.
 - Tubing with a 1/8" (.31 cm) inside diameter (I.D.) and, 1/4" (.625 cm) outside diameter (O.D.) - Vinyl tubing (VWR #63013-029), or Nalgene clear plastic tubing (Nalgene #8000-0020, VWR #63015-368)
 - Connector, 1/8" I.D., 1/4" O.D.

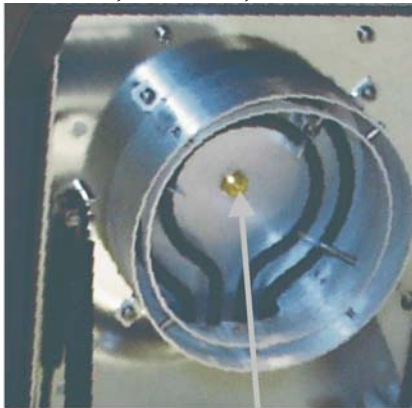

Remove plug and
install air diffuser inside.

Remove plugs and install
.007 and .012 orifice
fittings outside.



- Open the lid.
- Remove the plug that is centered in the heater ring.

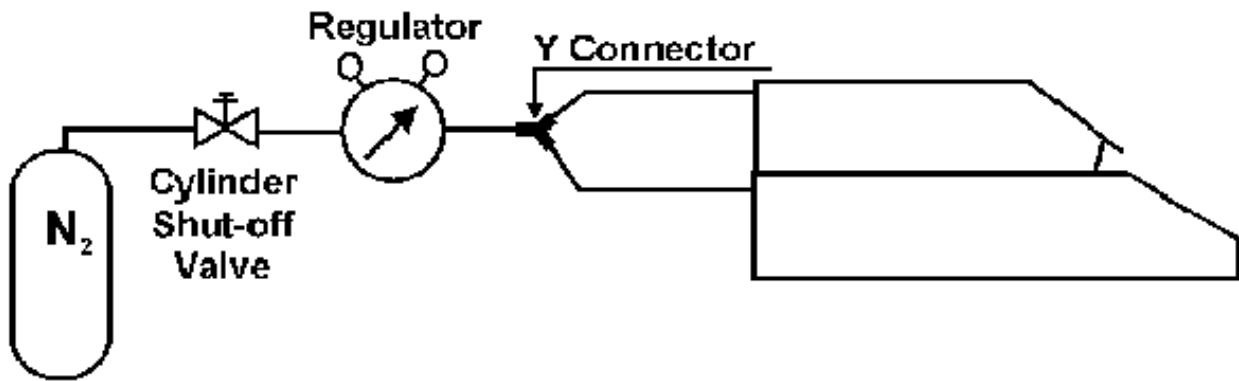

NOTE: Use caution when installing the air diffuser. Tighten it finger tight only to prevent breakage.



- Install the air diffuser and seal, supplied with the Nitrogen Purge Kit, into the opening created by removing the plug.
- Close the heater lid.
- From the back of the unit, remove the plug located in the upper left corner (as viewed from the rear) of the heater lid.
- Install the .007 orifice fitting (it has the green insert), supplied with the Nitrogen Purge Kit, into the opening created when the plug was removed.
- From the back of the unit, remove the plug from the lower portion of the unit.
- Install the .012 orifice fitting (it has the black insert), supplied with the Nitrogen Purge Kit, into the opening created when the plug was removed.
- Connect the regulator to the gas source/cylinder per the regulator manufacturer's instructions.
- Use tubing to connect the outlet of the regulator to the “Y” connector supplied with the Nitrogen Purge Kit.
- Connect tubing from the “Y” connector’s two outlets to the fittings on the rear of the unit.
- Check that all fittings are gas tight and secure. Pressure should be deferred until the start of a test to conserve gas use. Flow rates will be sufficient with the pressure set to between 4 and 5 psi.

5.8. Connecting a Printer



An optional graphic-capable printer is available from AZI (pictured is printer example only). It connects to the printer port at the rear of the instrument. The content and time of printing for each message can be custom configured from the menu system. These same messages can be directed to a computer through the RS-232 serial port at the back of the instrument.

- Unpack the printer, cable and paper. Install the paper according to the instructions in the printer manual. Plug the large end cable connector into its mating socket on the printer, and the small end into its mating socket on the back of the MAX 1000. Plug the power cord into the printer, and into a GROUNDED power receptacle.
- Turn the printer power on. (On some older printers it is also necessary to place the printer “On Line.”)

NOTE: If the printer is supplied with the MAX 1000 from AZI, the unit is already programmed. If the printer is obtained from another source, refer to its manual for programming information.

- To set up the MAX 1000, begin at the OPENING MENU and press [**Menu**]. Press the [**Down**] key until SETUP MENU is highlighted and press [**Select**].
- Highlight PRINTER SETUP and press [**Select**].
- Highlight PRINTER TYPE and press [**Edit**], to allow the selection to be changed. Press [**Incr**] or [**Decr**] to change the selection between available types. When the correct type is displayed, press the [**Accept**] key to lock the selection into the MAX 1000 parameters.
- Move the select bar to OUTPUT PORT and press [**Edit**], to allow the selection to be changed. Press [**Incr**] or [**Decr**] to change the selection between **LPT** for printer only, **RS-232** for Computer only, and **Both** for the printer and computer at the same time. When the correct port selection is displayed, press the [**Accept**] key to lock the selection into the MAX 1000 parameters.
- Move the select bar to AUTO FORM FEED and press the [**Toggle**] key to select between OFF and ON. When the correct selection is displayed, press the [**Esc**] key several times until returned to the MAIN TEST SCREEN. NOTE: Selection will depend on the printer used. Try Auto Form Feed ON for most printers. If the printer seems to waste paper, switch it to OFF.
- With the MAIN TEST SCREEN displayed, press the [**Menu**] key to display the MAIN MENU. Go down to the SETUP menu and press [**Select**]. Highlight REPORT SETUP and press [**Select**] again. With REPORT CONTROL OPTIONS highlighted, press [**Select**] again.
- With REPORT ENABLED highlighted, press the [**Toggle**] key, to select between YES and NO. Select YES to send the test results to the printer and NO to stop results from being sent to the printer.
- Highlight REPORT START and press [**Edit**]. Press [**Incr**] or [**Decr**] as necessary to select either START TEST, 1st PRED (first prediction), or TEST END.

- Press [**Acpt**] to save the selection in memory.
- Highlight REPORT INTERVAL and press [**Edit**]. Press [**Incr**] or [**Decr**] to select an interval between the minimum of 02 seconds and the maximum of 99 seconds. Press the [**Quit**] and the [**Acpt**] keys to lock the selection into the MAX 1000 parameters.
- Press the [**Esc**] key to return to the REPORT SETUP MENU.
- Move the select bar to REPORT ITEMS TO PRINT and press the [**Selct**] key. Move up and/or down through the list and use the [**Toggle**] key to select the items to be printed.
- Press the [**Esc**] key until the MAIN TEST SCREEN is displayed.
- To verify that the MAX 1000 and the printer are connected and working together, perform a weight test and monitor the printing operation.

5.9. Connecting a Computer

If you wish to monitor the test with a computer, connect a null modem cable to the smaller of the two "D" connectors at the rear of the instrument. Use any serial port communications program (not provided) on your computer to read the messages emitted at the MAX 1000 serial port. The content of each message can be selected from the REPORT ITEMS TO PRINT menu which is described on page 37.



- The MAX 1000 comes equipped with RS-232 communications available at a 9-pin standard serial communications socket at the rear of the instrument. The standard communications parameters used are 9600, N, 8, 1 (9600 baud, no parity, eight data bits, one stop bit). Refer to your computer communications program manual for instructions on configuring the PC to read this data format.
- The MAX 1000 does not test to see if the connected device is actually ready (or even present), nor does it respond to a request by the connected device for status information.
- Since the MAX 1000 can send data to both the RS-232 port and the parallel printer port at the same time, the same procedure to direct the output to the printer routes the output to computer.

5.10. Test Procedure

This section briefly describes the steps in running a test on a product sample.



CAUTION:

Mechanical stops offer some limited protection to the balance mechanism from overload damage caused by vertical forces. To prevent damage to the balance, use care not to push, pull, twist, turn or bump the sample pan support excessively.



- Obtain a sample of test material and transport it in an airtight container to prevent moisture gain or loss through contact with the atmosphere.
- If the instrument has already been configured for your test material, simply place a clean sample pan on the pan support, press **[START]** and follow the instructions displayed on the screen. If not set up, the material parameters must be entered before accurate testing may begin. See the PERFORMANCE ENHANCEMENT section that starts on page 42 and the MENU SYSTEM section that starts on page 25 for how to store the test setup for future use. Call your technical sales representative at 1-800-528-7411 or 1-602-470-1414 for assistance in installing your parameters.
 - Install a clean dry sample pan and press **[START]**.
 - When LOAD SAMPLE appears on the display, add sample.

NOTE: If the instrument displays LOAD SAMPLE, but the balance stored a tare weight greater than +/- .003 grams, press “ START” key again. If it will not zero, quit the test and start again.

- Load the sample taking care to distribute it evenly across the entire surface of the pan to get the fastest and most accurate results.
- After **[START]** has been pressed, a weight error message may appear on this screen. For example, if no pan or pan support is on the balance, UNDERLOAD will be displayed. If the weight on the sample pan exceeds 40 grams, OVERLOAD will be displayed. If an empty sample pan is in place, and either of these displays appear, turn the unit off and clean out any debris found beneath the pan support. Reassemble the parts and be sure that no mechanical interference is present. It may be necessary to calibrate the balance (see page 15). If these measures fail to restore normal function, call AZI customer service at 1-800-528-7411 or 1-602-470-1414 for assistance.
- The internal balance weight reading is always visible at the bottom of the screen when in the operating mode.

- While loading the sample, the weight is displayed in grams at the bottom of the screen and on a horizontal bar at the top. The target weight is entered under SAMPLE SIZE OPTIONS. Add the sample so that the solid bar is at or near the target weight and the instrument produces audible beeps.
- Close the lid to begin the test.
- While a test is in progress, the horizontal bar is not displayed. Only the weight in grams is displayed at the bottom center of the screen (shown as +08.0000 grams).
 - To load difficult samples more easily, remove the sample pan from the instrument after the correct amount of sample has been placed on the pan and place the filled pan on a level work surface. Spread the sample with a small flat brush or spatula, depending on the consistency of the sample.
 - Replace the loaded sample pan on the pan support and close the cover.
- To determine analyzer performance on a new product sample, repeat each test five (5) or more times to obtain reliable information about the standard deviation of a typical result. The test results are automatically retained until the next test is started. Copy the results from the Main Test Screen or from the STORED DATA MENU. Calculate the mean, standard deviation, and coefficient of variation using a computer or scientific calculator programmed for statistical data calculations.

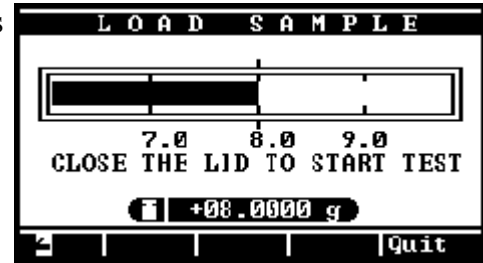

5.11. Test Data Output

- Test results are displayed on the Main Test Screen between tests or the Data Screen during a test. Test results may also be sent to a printer or to a computer. For printer output, connect a standard PC parallel printer to the MAX 1000 printer port. For communications with a computer, connect a null modem cable between the MAX 1000 RS-232 port and a computer running communications software. Call AZI customer service at 1-800-528-7411 or 1-602-470-1414 for assistance or more information on this software.

6. MENU SYSTEM: INSTRUMENT CONFIGURATION AND OPERATION

The MAX 1000 is controlled by various parameters and commands entered into the instrument by way of keyboard operations as prompted by the display. The entire set of commands and displays is accessible through a menu tree with each choice selected at the time of need by specific keystrokes.

The Main Test Screen, which appears a few seconds after the instrument is powered up, displays the current date, time, last test parameter set name, last test result, last elapsed test time, and the idle temperature setpoint as shown below. It is also the top of the menu tree and displays the name of the four functions selectable by the four arrow keys.

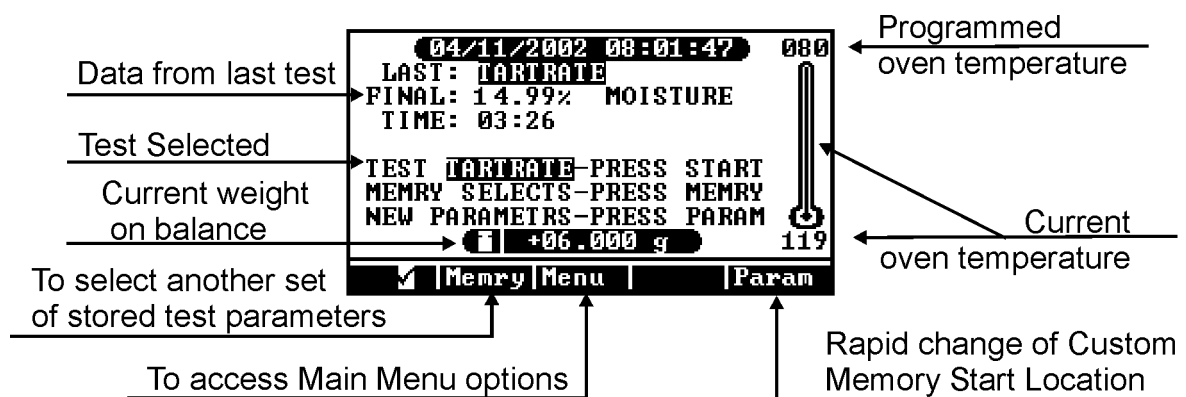

- The left-most selection is [**Memry**] and will switch the display to a list of stored test parameters (Memory Starts).
- The next selection is [**Menu**] and will switch the display to the Main Menu from which most test parameters and functions are accessed.
- The right-most selection is [**Param**] and allows the parameters of the Memory Start Test at ID:006 CUSTOM, to be changed quickly between tests.

If access code control is active, edits to some components of the menu system will bring up a message asking for the access code. For more information on the access code, see page 38.

6.1. MAIN MENU

At the Main Test Screen, pressing the [Menu] button will display the four top-level selections of the menu system.

- **MEMORY START MENU** is used to make changes to Memory Start stored parameter sets.
- **STORED DATA MENU** is used to view, and/or, print, data from the last moisture test.
- **CALIBRATION MENU** is used to perform calibrations.
- **SETUP MENU** is used to enter and/or edit instrument default parameters for the printer, reports, internal clock, data format, and the access key, or codes, used to control parameter change access.
- The four arrow keys, [◀], [▶], [▲], and [▼], are used to navigate through the menu system, and to respond to prompts on the screen. To select a menu item, move the selector bar up or down the displayed list to the desired function using the [▲], or [▼], arrow keys. If the list is longer than can be displayed on a single screen, a scroll bar will be displayed at the far right of the screen. Arrows on the scroll bar will indicate available screens, below and/or above the current screen. Press [Select] to choose the option or move to the next menu level, or press [Esc] to return to the previous menu level.

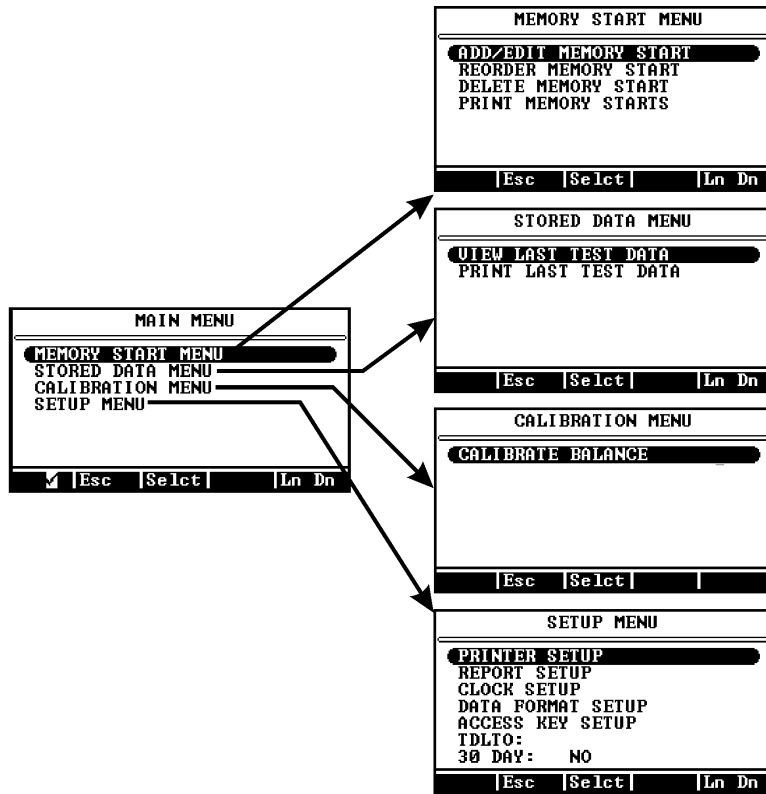

6.2. Memory Start Menu

The Memory Start Menu allows access to the stored test parameter sets. This is where the contents of the stored parameters may be printed out or changed.

Selecting any of the four options in the Memory Start Menu brings up the list of stored test parameter sets. They are sequentially numbered from 000 to 006.

The first two, 000 ID: WEIGHT and 001 ID: TARTRATE, are factory-set in non-volatile memory and cannot be changed.

The last, 006 ID: CUSTOM, can be changed through this menu or using the [Param] key at the Main Test Screen.

➤ Add/Edit Memory Start

Used to create or alter a stored set of test parameters. The seven options/parameters available at each memory start selection are discussed in the following paragraphs. Once a selection is made, follow the displayed screen prompts to complete the editing process.

⇒ Sample Name

An eight place alphanumeric identification for the test. Each ID location will be blank when first opened. Edit the value to any desired name or number to identify the product under test.

⇒ Temperatures

The three possible temperature parameters used during a test.

Test Temperature

The current temperature setpoint is displayed after TEST TEMPERATURE. Press [Edit] and the cursor will be positioned at the first (most significant) digit. Use the up or down arrows to increase or decrease the digit value. Press the right arrow key to move to another digit, and change each appropriately.

When finished, move the cursor to the end digit and (press the key labeled [Quit]. To register the change, press the key labeled [Accept]. To cancel the change, press the key labeled [Cancel]. The display remains at the TEMPERATURES screen.

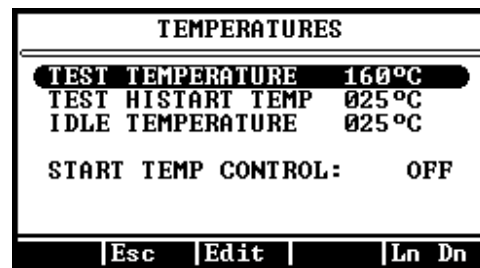
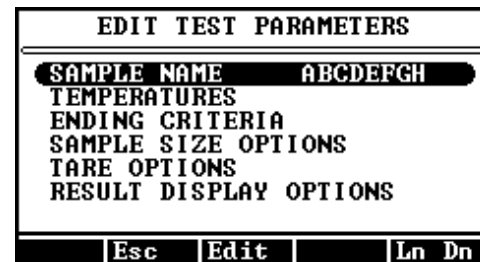
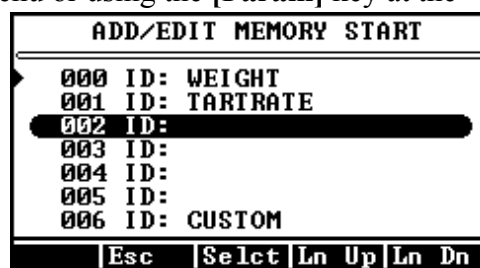

Test Histart Temperature

Gives two temperatures for a test, one higher at the beginning and one lower part way through the test

- The instrument begins a test at the HISTART TEMPERATURE, and continues at that temperature until the rate of moisture loss falls to half of its peak value. The heater then changes to the test temperature setpoint for the remainder of the test.
- The MAX 1000 prediction algorithm is so fast, this process is usually not necessary.
- To deactivate the HISTART feature, set the TEST HISTART TEMP to 25°C.

Idle Temperature

The temperature maintained by the instrument between tests. This speeds testing, by decreasing the time required to heat the sample chamber at the beginning of the test. It can save 10 to 90 seconds of test time if properly used. A common idle temperature value is 50°C but any value above room temperature (but below 150°C) can be used. Experiment to see what value is best for your application. Too high a value will cause low results because the sample is evaporating while the basis weight is being measured at the beginning of the test.

Start Temp Control

Prevents a test from starting if the chamber temperature is more than two degrees hotter or colder than the IDLE TEMPERATURE. This feature can improve the standard deviation of results of some temperature sensitive materials. When this feature is enabled (on), and an over or under chamber temperature is detected, an alarm will sound and the test will quit.

If [START] is pressed when the chamber is too hot, the alarm will sound and the following message will be displayed: “CHAMBER TEMPERATURE IS HIGH. Open the lid and wait for the alarm.” Open the lid. An alarm will sound as the temperature reduces an appropriate amount below the idle temperature. Close the lid and press [START]. The alarm will sound and the “CHAMBER TEMPERATURE IS TOO LOW” warning will sound. Keep the lid closed and the alarm will sound again when the temperature has risen to within two degrees (2°C) of the set idle temperature. Press [START] and this time the test will proceed normally.

If [START] is pressed when the chamber is too cold, the alarm will sound and this message appears: “CHAMBER TEMPERATURE IS LOW. Leave lid closed and wait for the alarm then re-start test.” The alarm will sound again when the temperature has risen to within two degrees (2°C) of the set idle temperature. Press [START] to begin the test.

When the TEMP CONTROL is disabled (off), a test can be started at any temperature.

⇒ **Ending Criteria**

Used by the instrument to automatically end a test. This feature makes it unnecessary for the operator to monitor the analyzer while it is performing a test. Selecting this option will display the two ending criteria options.

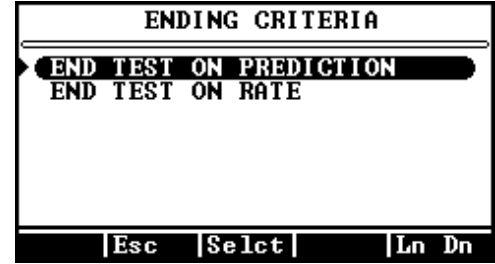

End Test on Prediction

The test will end when the predicted final value meets the selected condition.

TIGHT is the most accurate ending criteria but takes the longest time.

RELAXED is the least accurate ending criteria but is the fastest.

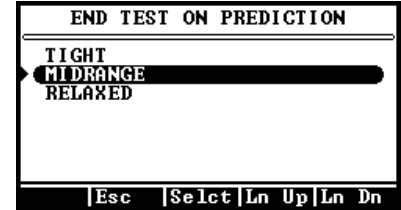

MIDRANGE ending criteria gives excellent results in an average amount of time.

End Test on Rate

This feature ends the test when the weight loss rate falls below a selected value. This value is a “percent per minute.” For example, entering 0.10 means that the test will end when the rate of change of the actual weight loss per minute is less than 0.10 % of the original sample weight.

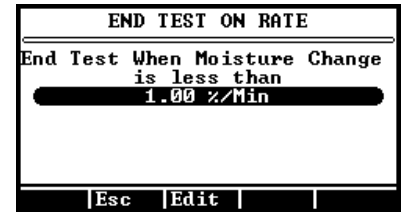

The instrument's program assumes that the sample contains volatile material that will completely evaporate after some time. It further assumes that the rate will increase to a maximum point and then gradually decrease to zero. Selecting some threshold rate value will cause the test to end before the sample is completely dry. Rate is useful to profile a sample's weight loss. Some applications are faster in the rate ending criteria. Others are faster in the prediction ending criteria.

Some samples contain more than one volatile material, for example nylon resins with large amounts of unpolymerized material (Caprolactam). In these cases the rate will fall to some fixed value when all the moisture is evaporated but while the monomer is still evaporating. The rate ending criteria, set just above the rate of monomer volatilization, may give the best results.

⇒ **Sample Size Options**

This feature enters target sample size and the minimum and maximum sample range. Sample size ranges can be programmed from 2 grams to 39 grams. The Sample Window can be from 0.5 to 19.5 depending on the sample size. The total of Sample Size plus Sample window cannot cause a negative number or equal 40 grams.

SAMPLE SIZE OPTIONS	
SAMPLE SIZE	2 g
SAMPLE WINDOW	± 0.5g
INSIDE LIMITS	TWO BEEPS
OUTSIDE LIMITS	NO BEEPS
Esc Edit Ln Dn	

Sample Size

The sample size should be consistent for all tests on a particular product in order to get the best standard deviation possible. High volatile materials, such as coatings, typically require smaller sample sizes (one to three grams). Low volatile materials, such as low moisture resins, typically require sample sizes from 20 to 30 grams. Contact your technical sales representative for appropriate sample sizes.

SAMPLE SIZE OPTIONS	
SAMPLE SIZE	20 g
SAMPLE WINDOW	±19.5g
INSIDE LIMITS	TWO BEEPS
OUTSIDE LIMITS	NO BEEPS
Esc Edit Ln Up Ln Dn	

Sample Window

The numbers entered set the center and tolerance values of the horizontal weight scale that is displayed when sample is being added.

SAMPLE SIZE OPTIONS	
SAMPLE SIZE	39 g
SAMPLE WINDOW	± 0.5g
INSIDE LIMITS	TWO BEEPS
OUTSIDE LIMITS	NO BEEPS
Esc Edit Ln Up Ln Dn	

Inside Limits and Outside Limits

Selections of no sound, one beep or two beeps may be programmed to signal inside or outside tolerance of sample quantity.

⇒ **Tare Options**

There are two tare options that define how stable the balance must be before a test will start. The third tare option is labeled Special Options and is used to tare a syringe, foil tray or other lightweight device used to carry or hold the sample on the pan.

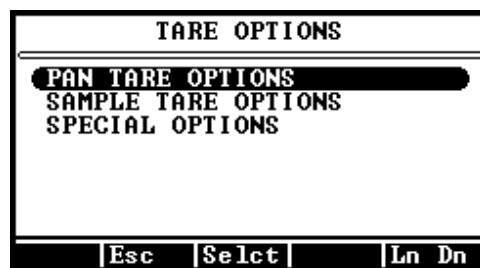

Pan Tare Options

This ensures that the drift in the measured weight of the empty pan is less than a given number. Pan Tare refers to the first step in a moisture test, the taring of an empty sample pan. Temperature fluctuations occur across the balance and are dependent on a number of different criteria such as previous test setpoint temperature, the amount of cool down time between tests, and the current idle



temperature. This temperature fluctuation causes the balance to drift during and after the sample pan tare and is reflected as error in the final moisture value. Since the conditions that cause the temperature fluctuation across the balance are not always constant, this error often appears as a higher standard deviation for a series of tests on a particular sample.

The Pan Tare Option offers the user four mutually exclusive selections to adjust the relationship between tare-time and tare-error to improve overall operation for a given product or purpose. The following table summarizes the menu choices and the parameters associated with each choice.

MENU CHOICE	INITIAL TARE TIME	POTENTIAL DRIFT ERROR	POTENTIAL TARE TIME
FAST	6 seconds	Up to 20 mg	6 seconds
STANDARD	6 seconds	1.0 to 2.0 mg	UP to 60 seconds
LOW MOISTURE	18 seconds	Less than 1.0 mg	UP to 2 minutes
ULTRA-LOW MOISTURE	30 seconds	Less than 0.3 mg	UP to 3 minutes

The FAST tare option, as the name implies, is the fastest. If this option is selected, the MAX 1000 zeros the balance, waits six seconds, and records the balance reading as tare weight. There is no check for balance drift. This option could cause the ending error to be as great as 20 milligrams.

The STANDARD, LOW MOISTURE and ULTRA-LOW MOISTURE options do check for balance drift caused by temperature changes and offer greater accuracy but at increased tare times. In these three options, the pan tare algorithm checks to ensure the balance has drifted less than 0.3mg during a variable TARE TIME (a few seconds to several minutes).

For example, a pan tare using the ULTRA-LOW MOISTURE option checks to ensure that the balance has drifted less than 0.3mg in the last 30 seconds after the tare command was issued to the balance. This requires that the balance be tracked for the initial 30 seconds.

If the drift is excessive at the end of that time, the balance is rechecked every six seconds, and the value is compared against the previous 30 seconds of data until the 0.3mg criteria is met. Depending upon the situation, an ultra-low moisture tare can take as long as three minutes.

The ULTRA-LOW MOISTURE Option should be used for samples with moisture content between 0.005 and 0.2 percent. This option may be used to improve accuracy for samples with moisture content in excess of 0.2 percent but will increase the overall testing time.

When the tare criteria have been successfully met, the balance is re-tared to zero and the unit beeps to indicate that it is ready for the sample to be loaded.

To select a PAN TARE OPTION, move the highlight bar to the desired choice and press [Selct]. To store the new selection, press [Esc].

Sample Tare Option

There are five possible choices under this menu. The factory default is START WHEN STABLE.

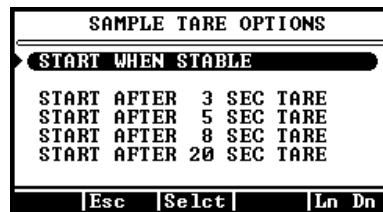

Start When Stable - The balance will start to tare after two seconds. Tare is complete and the test will begin when the balance is stable. The balance is stable when there is less than ± 0.3 mg difference in the weight measured on successive weight readings.

Start after 3 Second Tare: Test starts after a three second wait.

Start after 5 Second Tare: Test starts after a three second wait and five seconds of averaging.

Start after 8 Second Tare: Test starts after a three second delay and eight seconds of averaging.

Start after 20 Second Tare: Test starts after a three second delay and twenty seconds of averaging.

To select a SAMPLE TARE OPTION, move the highlight bar to the desired choice and press [Selct]. To store the new selection, press [Esc].

Special Options

Provides the means to tare a syringe.

Syringe Tare: Used when testing materials with high solvent or volatile content. The purpose is to account for the weight loss of material that normally would evaporate during the sample loading process.



An external balance with 00.001-gram (1.0 mg) resolution is used to weigh the syringe before and after loading. The difference in loaded and empty syringe weights is then calculated and entered into the MAX 1000 at the end of the test as the NEW START WEIGHT.

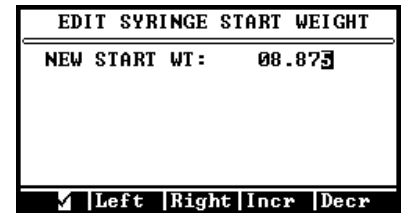

⇒ Result Display Options

Selects the final display value of moisture, solids or dry weight.

Test results can be displayed as a percentage of weight lost during the test (MOISTURE), percentage weight remaining after the test (SOLIDS), or as a dry weight (DRY WT) basis value. Dry weight basis is the weight loss divided by the weight remaining at the end of the test. Note that the dry weight value ratio can exceed 100%, and often does in applications such as soil and forest fuels analysis.

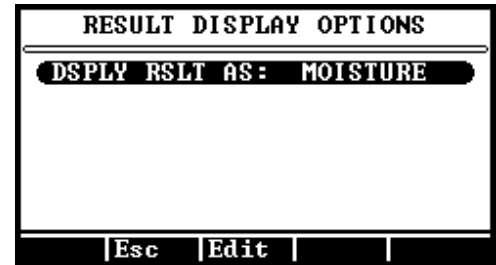

➤ Reorder Memory Start

Allows a stored parameter set to be copied from one position and pasted to another position in the list. If you paste a set over an existing set, the existing set is replaced and cannot be recovered. Be careful! To quickly create a new set similar to an old one, use REORDER to copy the old one to a blank location, then use ADD/EDIT to enter the new name and changed values.



➤ Delete Memory Start

This command removes a stored set of parameters. Remember to use this carefully as the information cannot be retrieved. The weight and tartrate parameter sets cannot be deleted with this option.

➤ **Print Memory Start**

This command prints the stored parameters. All seven (000 to 006) of the numbered Memory Start Sets are printed, giving the values of the parameters shown below in the print out example.

COMPUTRAC MAX1000 MEMORY START REPORT

#	ID	TST	IDL	HST	SSZ	SWN	MODE	RY	RATE
000	WEIGHT	105	025	025	8.0	1.0	PRED	00	
001	TARTRATE	150	100	025	8.0	1.0	RATE		0.03
002	TPO	125	100	025	20.0	2.0	PRED	00	
003	BROWN	115	050	25	9.0	1.0	PRED		
004	XXXXX	160	025	025	8.0	1.0	PRED		
005	XXXXXXX	160	025	025	8.0	1.0	RATE		1.10
006	CUSTOM	160	025	025	8.0	1.0	PRED		

The column headings are abbreviations for the following:

- # Identification number of the Memory Start Set
- ID Identification Name of the Memory Start Set
- TST Programmed Test Temperature
- IDL Programmed Idle Temperature
- HST Programmed HISTART Temperature Parameter
- SSZ Sample Size
- SWN Sample Window
- MODE Mode (Prediction, Rate, or Time) - End Test On Criteria
- RY Reliability Percentage - for End Test on Manual Prediction
- RATE Rate of Weight Loss - for End Test on Rate

6.3. STORED DATA (Not available on 21 CFR, Part II compliant instruments)

This function is used to work with data stored in the instrument from the last moisture determination. To access this function, go to the Main Menu and select the STORED DATA MENU.

➤ **View Last Test Data**

This function is used to view the data from the last test performed. The list is presented in abbreviated form consisting of the sample name, date and the final result. Pressing [Select] displays the targeted stability, reliability, tares and rate if they have been selected in the REPORT ITEMS TO PRINT menu.

➤ **Print Last Test Data**

Stored data can be printed to a parallel printer attached to the MAX 1000. That same data can also be routed to a computer. To print stored data, select that option on the STORED DATA MENU and press [Select].

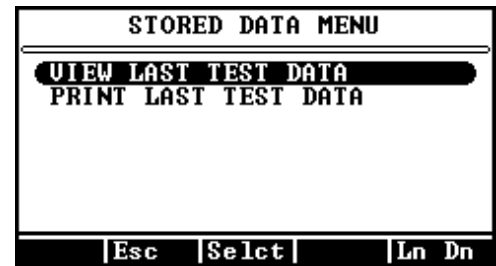

6.4. CALIBRATION MENU

The calibration menu provides access to the balance calibration routine.

➤ **Balance Calibration**

The balance should be calibrated immediately after initial setup, whenever the instrument is moved, whenever a problem is suspected or as set forth in your Quality Policy. See page 15 for the balance calibration instructions.

➤ **PRINT BALANCE CAL REPORT**

A printed copy of the calibration can be made by selecting the PRINT BALANCE CAL REPORT with a printer or computer connected to the instrument and the proper port selected under the PRINTER SETUP MENU.

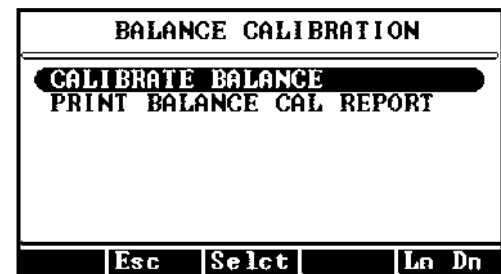
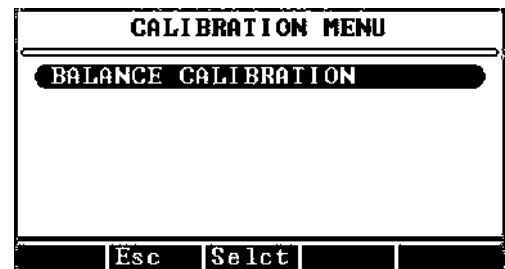

6.5. SETUP MENU

The SETUP MENU is used to program the MAX 1000 with information relevant to all operations and test. From the SETUP MENU it is possible to set up the Printer, Clock, Access Codes, Data Screen, and Company Name.

```
          SETUP MENU
-----
PRINTER SETUP
REPORT SETUP
CLOCK SETUP
DATA FORMAT SETUP
ACCESS KEY SETUP
TDLTO:
30 DAY:  NO
-----
| Esc | Selct | | Ln Dn |
```

➤ Printer Setup

Identifies the type of printer connected to the instrument, which port is to be used, and if an automatic form feed is desired. If the port option of “Both” is selected the data will be sent to the computer serial port and the parallel printer port.

➤ Report Setup

This menu allows for the program settings related to the final printout of a test. It is in this menu that the printer is enabled and the printout is customized to your needs.

⇒ Report Control Options

This screen controls output to the printer and the RS-232 port. It also controls how often the instrument sends data.

- Report Enabled: - Select YES to enable reports or NO to disable reports.
- Report Start:
 - ◆ START TEST – reporting will begin as soon as the sample tare is complete.
 - ◆ 1st PRED – reporting will begin when the first prediction is made.
 - ◆ TEST END – reporting is delayed until the test ends and real time data will not be printed during the test.
- Report Interval: Minimum of 02 seconds to the maximum of 99 seconds between reports.

⇒ **Report Items to Print**

The MAX 1000 can store data from the last test. These results are available for viewing or printing until the next test is started.

- MEMORY SELCT: Number of the memory start parameter set for this test.
- SAMPLE NAME: Identification tag for the parameter set used.
- LOT NUMBER: Identification tag for the lot of material to be tested now.
- PRODUCT ID: Identification tag for the product in this lot of tested material. Lot number and product ID are alphanumeric tags entered by the operator to identify a test, or set of tests, for reporting purposes.

- DATE: Date of the test.
- TIME OF DAY: Time of the test.
- FINAL RESULT: Test result value.
- RESULT TYPE: Moisture, solids or dry weight basis.
- TEST MODE: Ending criteria used for this test.
- START WT: Sample basis weight.
- END WT: Sample weight at the end of the test.
- TEST TIME: Minutes and seconds the test was in progress.
- START TEMP: Temperature of the chamber when the test started.
- TEST TEMP: Test setpoint temperature.
- HISTART TEMP: HiStart temperature setpoint.
- PAN TARE: Pan tare setting.
- SAMPLE TARE: Sample tare setting.
- SAMPLE CENTER: Nominal load weight.
- SAMPLE WINDOW: Acceptable load weight.
- END REL: Reliability ending criterion value at the end of the test.
- REL TGT: Target reliability used for PREDICTION ending criteria.
- END STAB: Stability ending criterion value at the end of the test.
- STAB TGT: Target stability used for PREDICTION ending criteria.
- END RATE: Rate ending criterion value at the end of the test.
- RATE TGT: Target rate used for RATE ending criteria.

⇒ **Add/Edit Company Name**

Allows the report headers to be customized to show the name of the company, test location, or other alphanumeric material.

➤ **Clock Setup**

Used to enter the correct date and time into the instrument's clock system. The internal battery saves the clock value when the power is off. Use this function to change the time at initial setup, when changing for daylight savings time, or when the internal battery is replaced. If the clock resets (or if all memory resets, in fact) whenever the power is off, the internal backup battery may need replacement. If this happens, call AZI customer service at 1-800-528-7411 or 1-602-470-1414.

➤ **Data Format Setup**

Controls functions from two possible selections that do not fit into other menu selection criteria.

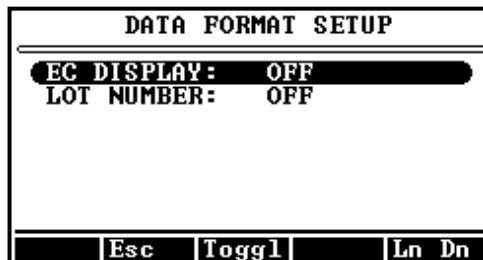

⇒ **EC Display**

The Ending Criteria (EC) Display controls display of the PREDICTED END POINT and the ENDING CRITERIA on the Main Test Screen during the test. Display of these values is useful during parameter development, to aid in selecting the best ending criteria to use for a particular test material. These values serve little purpose, however, during normal operation and may even cause confusion.

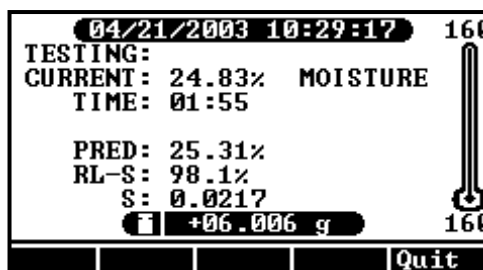

⇒ **Lot Number**

If the LOT NUMBER function is toggled ON in the DATA FORMAT SETUP menu, initializing a material test will bring up a screen labeled EDIT LOT AND ID NUMBER. There are ten spaces for the alphanumeric label characters. Each space can be changed with the arrow keys. Pressing [**Incr**] starts at "A" and continues through the alphabet, the symbols, and the numbers. Pressing [**Decr**] inserts numbers first (9 to 0), followed by the symbols, and finally the letters. Select the item to be edited with the up and down arrow keys, and press [**Edit**]. Press [**Quit**] when editing is complete. Press [**Acpt**] to record the change or [**Cancel**] to leave it unchanged. The instrument will retain and report the additional information.

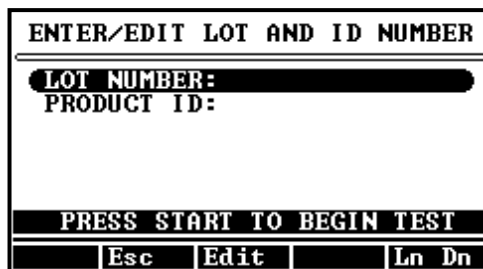

➤ **Access Key Setup**

Allows entry of access codes to prevent unauthorized user's entry into any menu where data can be edited, modified or deleted. The use of this option still allows all information menus to be accessed, viewed and printed by any user.



- A master key code permits access to all menus whether they are controlled by individual key codes or not. If the master key code is forgotten, call AZI customer service at 1-800-528-7411 or 1-602-470-1414.
- To enter or edit the master key code, highlight EDIT MASTER KEY and press [**Edit**]. Use the arrow keys to enter or edit a master key code of up to eight (8) characters.

- In addition to the master key code, the system allows a calibration key code to be entered so selected users can calibrate the instrument but not have access to other protected menus. To enter or edit this code, highlight the EDIT CAL KEY and press **[Edit]**. Use the arrow keys to enter or edit a parameter key code of up to eight (8) characters.
- To activate the access key codes, highlight ACTIVATE KEYS and toggle the NO to a YES. To deactivate the access key codes, highlight the ACTIVATE KEYS and toggle the YES to a NO.

7. MEMRY - MEMORY START SELECTIONS

Pressing **[Memry]** will display the STORED PARAMETER SETS, more commonly called “Memory Starts” that are used to perform repeated moisture tests of various materials.

- Memory Starts are numbered at the left, beginning with 000. A total of seven different parameter sets can be retained in the system memory. Each has a unique number, and a user entered ID label. Memory Starts 000 Weight Test and 001 Sodium Tartrate are preprogrammed for system verification. These are stored in non-volatile memory and cannot be changed. Memory Start 006 is the CUSTOM parameter set. The instrument uses this set when first powered up, if no other memory start parameter set has been programmed and selected. This location is also used to store temporary parameter sets entered after pressing **[Param]** on the Main Test Screen.
- Memory Starts 002 though 005 are programmed by the user through use of menu options to set the parameters into the instrument for specific material that is to be measured on a recurring basis.
- To begin a test using a Memory Start stored parameter set:
 - Press **[Memry]** at the Main Test Screen.
 - Move the selector bar to the desired stored test parameters set with the up and down keys, and press **[START]**.
 - Unless the LOT NUMBER function is selected the test will start immediately using the parameters stored in the instrument for under the selected material.

8. PARAM: TEMPORARILY CHANGING TEST PARAMETERS

To develop a new application, a few tests are run with different values for parameters such as temperature and sample size. Ending criteria and sample size are also changed to improve speed and accuracy. To speed this process, the Param function allows immediate alteration of a test parameter and immediate execution of a test from the parameter change screen. This parameter change function is only available for the parameter set stored in Memory Start 006, entitled CUSTOM.

To quickly change a parameter, press **[Param]** at the Main Test Screen. Enter the access code, if needed, and the PARAMETERS MENU START screen will appear. Make the necessary changes to the listed parameters, including a unique sample name to help identify different test runs, and press **[START]** any time to begin a test with the altered parameter values.

9. MISCELLANEOUS MESSAGES

9.1. Control Program Version Number

For troubleshooting purposes, AZI customer service may need to know the version (or revision) of the control program running in your instrument. To display this information, turn the power off, wait a second, and turn it on again. Observe the front panel. The program version number will be displayed in the lower center portion of the screen for about five seconds.



MAX 1000
Copyright 2002
Arizona Instrument
Version 4.2X

9.2. Diagnostic Failure Messages

The MAX 1000 contains extensive diagnostic software, which monitors the performance of the instrument. If a dangerous or abnormal condition is detected, the instrument turns off power to the heater, ends operations, locks the keyboard and displays the following message:

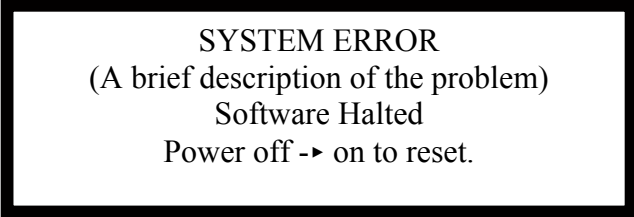

SYSTEM ERROR
(A brief description of the problem)
Software Halted
Power off -> on to reset.

Record the error message and turn the power switch to off. Wait ten seconds and turn the power switch back on. If cycling the power switch does not clear the error, stop using the instrument and call AZI customer service at 1-800-528-7411 or 1-602-470-1414.

10. PERFORMANCE ENHANCEMENT

NOTE: The information presented here is general in nature.

The Computrac MAX Series loss-on-drying moisture analysis system takes advantage of computer technology to reduce test times and increase precision over standard vacuum oven or convection oven drying procedures. The sample is added to an aluminum sample pan sitting atop an electronic force balance within a test chamber. As the sample heats and loses weight due to moisture evaporation, the balance records that weight loss and transmits the data to the microprocessor. The microprocessor interprets the information and compares the sample's weight loss to a standard drying curve. The final moisture concentration is extrapolated from the curve and results are available within minutes.

A typical drying curve consists of three portions:

- The first portion (A-B) represents the sample's weight loss as it heats from room to testing temperature.

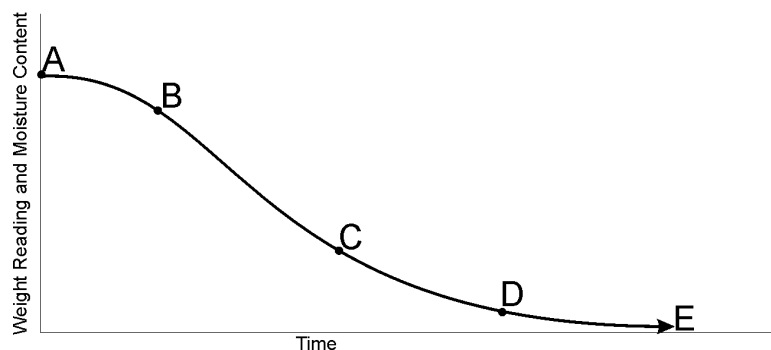

MAX-1000 Drying Curve

- Section B-C is linear, representing moisture loss from the interior of each particle of the tested sample. The final portion of the curve (C-D) is exponential in nature and represents the final evolution of moisture from within the particle. The point at which no additional weight loss occurs represents the complete evolution of water from the original sample (E).
- The final portion of the curve (D-E) is the longest and most time-consuming portion of the entire testing process. The time for a sample to reach zero residual moisture in an oven can take from one to possibly 24 hours depending upon the sample, sample preparation, and testing temperature. The MAX 1000 loss-on-drying system calculates the sample's moisture concentration through mathematical extrapolation from the exponential (C-D) portion of the curve.

The aluminum pan sits on a pan support coupled to a sensitive electronic force balance. The force balance registers the initial weight of the sample before testing and relays the sample's decreasing weight to the microprocessor for evaluation. Balance readings are averaged to eliminate signal interference or erroneous data.

Within each memory start, test temperatures can be programmed between ambient (25°C) and 225°C in either a one or two-step temperature contour. Heating is done through a 700-watt nichrome element, which is located on the underside of the test chamber's lid. An RTD monitors the temperature of the test chamber and sends that information back to the microprocessor. Under the microprocessor's control, the heater element is cycled on and off to bring the test chamber to the programmed level.

During the entire testing process the microprocessor monitors the sample's weight loss. The sample's decreasing weight is compared to the initial sample weight and the calculated moisture concentration will appear on the display. Simultaneously, the microprocessor is predicting a final moisture concentration based upon the sample's rate of weight loss compared to the exponential portion of a standard drying curve. Testing will continue until the predicted moisture concentration agrees within a certain percentage of the actual moisture concentration appearing on the display. The percent agreement between the predicted and the actual moisture concentrations will vary depending upon the system's programming and the moisture level of the sample.

The MAX 1000 is an extremely flexible instrument. This flexibility means that some time is required to determine the best set of parameters for a particular application. The determination of the proper parameters requires a series of tests, and good laboratory procedure. Call your AZI technical sales representative at 1-800-528-7411 or 1-602-470-1414 for assistance.

10.1. Selection of Test Temperature

If the moisture of the sample material is known, as determined by a reference method (vacuum or air oven), the MAX 1000's temperature can be adjusted until test results correlate with the established moisture concentration. If the moisture is not known, prepare a moisture versus temperature curve to decide the proper test temperature for a particular sample. Sample material is tested at increasing ten-degree temperatures increments.

The starting temperature is usually the standard or reference method temperature for that particular sample. Results for each increasing temperature will usually rise to a plateau where several increasing temperatures do not change the results significantly. Beyond this plateau results rise dramatically.

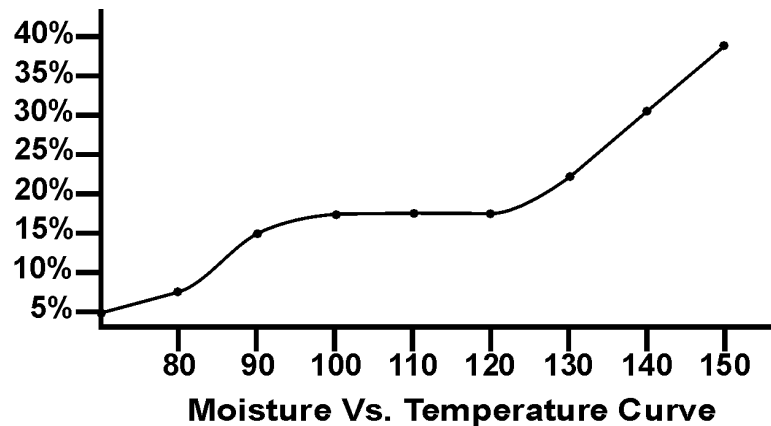

Examination of a sample, tested at these increased temperatures, shows burning or charring.

Results along the plateau usually correlate well with the standard or reference method results. Repeated testing should be done at temperatures in this range. Several tests are performed using the same sample size and test parameters. Results from these repeated tests are tabulated to calculate the mean, or average, and the standard deviation (S.D.). Analysis of the mean and standard deviation, and their comparison with reference method results, determines that the proper test temperature has been used. If mean values do not compare well, or if the standard deviation is too large, test at another temperature along the plateau.

10.2. Selection of Ending Criteria

The decision of which ending criteria to use is application dependent. Best results are typically given with the PREDICTION for some materials and RATE for others. Experiment with your particular sample to determine which criterion is best for your product.

For END TEST ON PREDICTION, the MAX 1000 uses one of three criteria to end a test. TIGHT is the most accurate but takes the longest time. RELAXED is the least accurate but takes the shortest time. MIDRANGE gives excellent results in an average amount of time.

For END TEST ON RATE, the MAX 1000 ends the test when the sample weight loss rate has fallen below a preset percentage value. This is useful for samples that do not conform to the standard exponential drying model but will show a consistent moisture rate loss at some point in the process. The parameter may be set for values from 0.01% to 9.99% loss rate.

10.3. Preparing Granular and Powdery Samples

The MAX 1000 system can be used to test a wide range of products from finely ground, low-moisture powders to high-moisture slurries. **For best results, the sample should be of a uniform particle size distributed evenly over the sample pan.** If sample material is collected into a jar or sampling bag, shake the jar or bag to produce a uniform mixture. Liquid samples should also be mixed or shaken to ensure a more homogeneous mixture. Large chunk samples, such as charcoal or cookies, should be crushed or ground to smaller pieces approximately 1/4" or less in diameter.

Some samples, such as dried vegetables, may also need to be ground. The smaller pieces will easily release moisture during testing, leading to shorter test times and more repeatable results. Solid, granular sample material should be shaken onto the pan from a spoon; shaking sample directly from the collection jar will usually deposit only the larger granules, not a representative mixture. Liquid samples or slurries can be spooned or poured onto the sample pan; however, a pipette or sampling straw will collect a more uniform mixture of the sample. All samples should be evenly distributed over the sample pan.

10.4. Preparing and Testing Liquid Samples

Some liquid samples will dry slowly, even at high temperatures. Drops or puddles, which dry slowly in this type concentration, may form on the pan. A skin may form over the sample, which limits evaporation from the interior. Long test times (greater than 25 minutes) and low percent moisture (or high percent solids values) suggest incomplete drying. Pre-dried glass-fiber filter paper and flat-bottom pans are recommended to successfully test samples such as these.

- The glass-fiber filter paper, AZI P/N 990-0003, serves as a support for the liquid sample. The sample is absorbed through the paper for more even and rapid evaporation to reduce test times.
- Waffle-bottomed sample pans are not recommended for use with filter paper. The liquid sample may soak through the filter paper and collect in puddles in the pan's depressions. Flat-bottom pans are available from AZI as part number 990-0010. Call AZI parts sales at 1-800-528-7411 or 1-602-470-1414 to order.

Occasionally, some samples cannot be absorbed into the filter paper. At the end of the test, examination of the sample pan shows the sample sitting high above the filter paper with a thick crust. The crust may be singed from the heat or even show bubbling where vapor has been trapped beneath the surface. % SOLIDS results will be high or % MOISTURE results will be low. Samples such as these are treated differently: After the sample has been added to the sample pan, remove the pan from the test chamber and place it onto a flat surface. Grasp part of the filter paper (tweezers are suggested) and flip it over so that the sample lies between the pan and the paper. Squash the sample with a flat-bottom glass or jar to a uniform layer. Return the sample pan to the test chamber and close the lid. The upper filter paper surface absorbs moisture from the sample and minimizes bubbling and spattering to produce more accurate, reproducible results.

10.5. Selecting the Optimum Sample Size

Each particular sample will have its own optimum sample size. Best results will be obtained if the sample consists of a single layer of particles, as long as this is sufficient to develop a weight loss of 10 milligrams or more. A rule of thumb is "the lower the moisture, the larger the sample." Low-moisture samples, less than 0.100%, such as chemicals or plastics require larger amounts, 20 to 30 grams of sample. The larger sample size is necessary to provide sufficient weight-loss information to the microprocessor. A larger weight change between the initial and final sample weights will give more accurate, repeatable results. Smaller sample size will give faster tests. Generally, it is best to use a thin layer that just covers the surface of the pan. Very light, or very expensive test materials may require samples weighing as little as 150 milligrams. Be aware that the standard error will be larger for samples this small, unless the moisture content is sufficient to cause a weight change of 10 milligrams or more for each test. If the first result is too low, increase sample size or raise the temperature. If it is too high, decrease sample size, or lower the temperature.

The sample should be added evenly, in a thin layer, across the entire surface of the pan. Once the desired amount has been added, the pan can be removed from the test chamber to evenly distribute the sample. The sample should be distributed over the surface by gentle shaking, tapping, or for very viscous samples, spread with a spoon or knife. Do not spread granular products with a spoon as the particles compress even under gentle pressure, affecting test times and results. An even layer of sample across the pan will reduce test times and increase precision of results.

11. PERFORMANCE VERIFICATION

Periodic checks of the system are recommended to verify proper system operation. These periodic checks will satisfy some quality assurance requirements as specified in your quality assurance/control policy. A log is recommended, either hand written or computer managed, which will record the weight tests, sodium tartrate tests and retained sample results. Shifts in results that are out of range can be quickly detected and the appropriate corrections made.

11.1. The Weight Test

The test, listed on page 17, simulates moisture release with the removal of one of two known weights. This test may be used as part of your control verification program:

- At the interval established by your quality assurance/control program;
- Any time the unit is moved, the power switched off, the instrument is jarred or bumped; and/or
- If there is any concern about the accuracy of the instrument.

11.2. The Precision Weight Test

This is a series of weight tests and is a more critical verification of the instrument's accuracy.

- Perform the steps in the Weight Test a total of five (5) times.
- Mean, Standard Deviation, and Coefficient of Variation are calculated using the following formulas.
 - Mean = total of results divided by number of results.
 - Standard Deviation = $\sqrt{\frac{\Sigma(\bar{x} - x)^2}{n - 1}}$
 - Coefficient of Variation = Standard Deviation divided by Mean, times 100%
- The mean of the indicated weight loss percentage should be 37.500%, +/- .020% for a test using the five and three gram weights.
- If the results obtained from these tests are outside the specified range, call AZI customer service at 1-800-528-7411 or 1-602-470-1414 for assistance.

11.3. Sodium Tartrate Test

The sodium tartrate test verifies the heater and force balance operation. Sodium tartrate dihydrate is a chemical with a known moisture concentration that gives up moisture at temperatures greater than 120 °C.

Because of its consistent moisture concentration, it is used as a standard in moisture measurement using oven or titration methods. To obtain consistently reliable results, use a high quality or reagent grade (ACS certified) granular sodium tartrate. Grind sodium tartrate that contains lumps or has an uneven consistency. (Lumps in sodium tartrate usually indicate moisture absorption that will yield inconsistent results.) Sift the sodium tartrate through a #20 sieve to obtain a more uniform size that will achieve better results. Re-grind the larger chunks and return them to the bottle as well.

The test uses approximately 8 grams of sample and is run at 150 °C. Results should be within a range of ± 0.1 of the assayed value on the label of the chemical. (Sodium tartrate assayed moistures typically range from 15.61 - 15.71.)

-
- From the Main Test Screen, press [**Memry**].
- Highlight 01 ID: TARTRATE.
- Press [**START**] key.
- When the prompt OPEN THE LID appears on the screen, open the lid and carefully place a clean sample pan on the pan support.
- Close the lid and allow the unit to tare.
- When the OPEN THE LID prompt appears on the screen again, open the lid and gently and evenly shake sodium tartrate over the surface of the sample pan until the display shows that 7.9 to 8.1 grams of sample are loaded.
- Close the lid and the test will begin.
- Wait for the end of test signal.
- If this is the first test of the day, discard the results of this test for stability reasons.
- Results should be within a range of ± 0.1 of the assayed value on the bottle label.

11.4. Precision Tartrate Test

- Perform five (5) sodium tartrate tests.
- Mean, Standard Deviation, and Coefficient of Variation are calculated using the following formulas.
 - Mean = total of results divided by number of results.
 - Standard Deviation = $\sqrt{\frac{\sum(\bar{x} - x)^2}{n - 1}}$
 - Coefficient of Variation = Standard Deviation divided by Mean, times 100%
- The mean of the Tartrate results should be ± 0.1 of the value on the bottle label.
- If the result is out of tolerance, the most common causes of such errors are bent or dirty sample pans, or debris that may have fallen into the balance shaft. Switch the unit OFF. Remove the pan support and the balance cover. Carefully clean the instrument, see page 51. Also, clean the heater assembly and check the temperature sensor, see page 51.
- Repeat the tartrate test again, using a clean sample pan for each of the five samples, and calculate the results.
- If the mean is still out of tolerance, call AZI customer service at 1-800-528-7411 or 1-602-470-1414 for assistance.

11.5. Retained Samples

The weight test and the sodium tartrate test are usually sufficient to satisfy industry guidelines for quality control in moisture measurement. Some additional checks can be performed using replicate testing of retained samples. Retained samples, when stored under airtight conditions, should maintain moisture levels for long periods. Routine testing of these samples should produce the same results day after day. Retained samples further verify the unit's operation on the customer's own product. If hygroscopic materials are used, the values can change with time and repeated opening of the container.

- Let the system warm up for 20 minutes.
- Set the MAX 1000 to the optimum test temperature for the retained sample or use the ID Number of a test that has been stored in memory.
- Place a clean aluminum sample pan onto the pan support in the test chamber.
- Close the lid and press **[START]**.
- When the OPEN LID display appears, GENTLY add the optimum amount of retained sample evenly across the sample pan.
- Close the lid and allow the test to continue.
- Record the final result in the quality control log.
- The results for the retained sample should fall within the established acceptable range of results for that sample. If results are out of range, repeat the test to verify results and/or perform standard reference testing to certify the percent moisture value.

12. ROUTINE MAINTENANCE

The MAX 1000 requires routine cleaning to keep the test chamber free of excess sample material. Failure to keep the instrument interior clean reduces its accuracy and repeatability. Sample material collecting in the test chamber prevents free movement of the pan support. Also, sample material collecting on the heater shroud prevents the lid from closing completely, causing erratic moisture results. Material may fall into the system's interior, causing balance problems. Routine cleaning of the test chamber reduces the possibility of problems and repairs, extending the life of the instrument.

12.1. Chamber Interior

The chamber interior needs to be cleaned when needed to eliminate the buildup of sample material. Switch the main power switch off and use a vacuum line, portable vacuum cleaner, or a small paintbrush to remove debris from the chamber.



A compressed air line or canned air is not recommended since debris migrates into the system's interior and settles on the electronic components and in the balance.



12.2. Heater Cleaning

The MAX-1000 heater is calibrated when it is in a clean condition at the factory. If the test materials darken the heater shroud during use the reflective characteristics of the heater will change and its calibration will drift. Establish a periodic cleaning schedule to ensure the unit-to-unit and sample-to-sample correlation will remain acceptable. How often the cleaning occurs depends on the application and frequency of use.

The cleaning may be accomplished by:

- Wiping down the heater shroud on a regular basis, or for heavy accumulations,
- Sending the unit to Arizona Instrument for complete disassembly, cleaning, reassembly, and heater calibration.

The extent of cleaning required is determined by the extent of darkening and the accuracy required from the unit.

To wipe down the heater at your facility:

- Turn the MAX-1000 off.
- Remove the power cord from the power supply.
- Ensure the unit has cooled down to ambient temperature.
- Remove the sample pan.
- Use the supplied tweezers to remove the pan support up and out of the test chamber. Be careful since excess force on the balance may result in costly repairs.
- Cover the pan support hole in the bottom of the chamber with masking or other similar tape.
- Use a vacuum line, portable vacuum cleaner, paper towel, and/or small paint brush to remove debris from the chamber.



WARNING

An oven cleaner such as “Easy-Off” should not be used on the aluminum shroud as it is corrosive and will pit the aluminum. Do NOT use a heavy spray of any cleaner into the heater and/or shroud area. Excessive moisture could affect wiring and its insulation.



If the heater shroud darkens quickly, the unit-to-unit correlation and performance may be more consistent if the shroud is allowed to darken and then having the instrument calibrated to the darkened state by Arizona Instrument. Once a significant amount of darkening has occurred, the rate of change in the calibration is greatly slowed. The "browned" condition may be allowed to remain on the heater shroud and heater box if the test results are still within an acceptable range. The heater area may become so dark that a good calibration is not possible and the assembly must be disassembled, cleaned, reassembled, and temperature calibrated. Since the positioning of the heater coils and RTD are critical to accurate temperature control, the complete cleaning and calibration must be accomplished by Arizona Instrument or one of the factory authorized service centers. If this type of cleaning is required, call AZI Customer Service Department to arrange to return the instrument to the factory, or if multiple units are involved, a field service visit.

Call AZI Customer Service at 1-800-528-7411 or 1-602-470-1414 if you have any questions.

12.3. Sample Pan Support

The sample pan support may need to be cleaned if high volatile material condenses on it. Turn the unit off and use the supplied tweezers to remove the pan support up out of the test chamber. **Remove the pan support carefully and clean it by wiping with a tissue or paper towel.**

13. TROUBLE MESSAGES

Messages appear on the display screen when certain internal problems occur. You will probably never see one of these messages. However, if one should appear, the message and its meaning are provided in the following table. With each message, a probable cause and a suggested action to take is listed.

BAD EPROM CHECKSUM	The EPROM is continuously checked against a pre-calculated CHECKSUM to insure against failure. This message appears if a discrepancy is detected.
Probable cause:	Bad EPROM chip.
Action:	Replace U4; Call AZI at 1-800-528-7411 or 1-602-470-1414 for assistance.
SRAM	SRAM chip is continuously checked for proper operation during program execution. Message generated if error in SRAM detected.
Probable cause:	Bad SRAM chip.
Action:	Replace U3; Call AZI at 1-800-528-7411 or 1-602-470-1414 for assistance.
HEATER RUNAWAY	Message is generated if the lid is closed and temperature exceeds 290°C for 3 seconds. It is also generated if the lid is open, and the temperature does not decrease according to an exponential model.
Probable causes:	Failed triac or triac driver (may be both). Excess line noise
Action:	Use power line conditioner or isolated power line. Call AZI at 1-800-528-7411 or 1-602-470-1414 for assistance.
TEMPERATURE CIRCUIT	Message is generated if temperature circuit is not detected.
Probable causes:	Analog-to-Digital (A/D) Converter failure. RTD failure. Bridge circuit failure. MPU failure.
Action:	Check RTD connection to board. Call AZI at 1-800-528-7411 or 1-602-470-1414 for assistance.
A/D TIMEOUT	Message generated if A/D does not clear in 100mS.
Probable causes:	Bad A/D. Bad A/D timing circuit.
Action:	Call AZI at 1-800-528-7411 or 1-602-470-1414 for assistance.
INTERRUPT STARTUP	Something caused the system to crash and reset.
Probable cause:	RAM corruption of some kind.
Action:	Call AZI at 1-800-528-7411 or 1-602-470-1414 for assistance.

14. TROUBLE DIAGNOSIS

SYMPTOM	DIAGNOSIS	REMEDY
Answer always zero	Pan Support height incorrect	Adjust pan support height, see page 12 or call AZI at 1-800-528-7411 or 1-602-470-1414 for assistance.
	Temperature too low	Raise setpoint, see pages 27 & 44
	No heat	See No Heat symptom later in table
	Sample too small	Increase sample size, see pages 30 & 46
Answers vary too much	Test temperature incorrect	Determine temperature/ending criteria to use or call AZI at 1-800-528-7411 or 1-602-470-1414 for assistance.
	Ending criteria incorrect	
	Sample size too small	Increase sample size, see pages 30 & 46
	Samples not uniform or sample particles too large	Grind sample, see page 45
Blank display	Contrast controls not set	Adjust contrast, see page 14
	No power	Check power cord connections, see page 13
	Microprocessor failure	Turn unit OFF for 5 seconds and then turn it back ON. Call AZI at 1-800-528-7411 or 1-602-470-1414 for assistance.
	Backlight connector disconnected	Reconnect, call AZI at 1-800-528-7411 or 1-602-470-1414 for assistance.
Heat will not turn off	Circuit board failure	Call AZI at 1-800-528-7411 or 1-602-470-1414 for assistance.
Moistures too high	Temperature set too high	Lower temp, See pages 27 & 44
	Bent sample pan	Use new pan
	Dirty sample pan	Use new pan
	Debris in balance gaps	Call AZI at 1-800-528-7411 or 1-602-470-1414 for assistance.
	Dirty heater assembly	Clean heater assembly, see page 51
	Ending Criteria incorrect	Determine new ending criteria, see page 29. Call AZI at 1-800-528-7411 or 1-602-470-1414 for assistance.

SYMPTOM	DIAGNOSIS	REMEDY
Moistures too low	Temperature too low	Increase temp, see pages 27 & 44
	Sample size too small or too large	Adjust sample size, see pages 30 & 46
	Lift compensation too large	Decrease lift comp pct, See page
	Ending Criteria incorrect	Determine new ending criteria, see page 29. Call AZI at 1-800-528-7411 or 1-602-470-1414 for assistance.
Moisture never stops increasing	Other volatiles present	Lower temp, see pages 27 & 44
	Balance drifting	Call AZI at 1-800-528-7411 or 1-602-470-1414 for assistance.
No heat	Voltage selection wrong	Check power module at rear of instrument, set to correct voltage, see page 13
	Wiring failure in heater circuit	Call AZI at 1-800-528-7411 or 1-602-470-1414 for assistance.
	Heater failure	call AZI at 1-800-528-7411 or 1-602-470-1414 for assistance.
	Door sensor failure	Check display for LID OPEN message when open during a test, call AZI at 1-800-528-7411 or 1-602-470-1414 for assistance.
	Temperature setpoint too low	Raise temperature above room ambient or standby temperature, see pages 27 & 44
No power to instrument	Power switch off	Check switch position, Confirm power cord seating, Test circuit with lamp, Remove and test fuse, see page 13
	Power cord disconnected	
	Outlet not powered	
	Fuse blown	
No weight reading	Balance not initialized	Turn power off, then on, wait 15 seconds, call AZI at 1-800-528-7411 or 1-602-470-1414 for assistance.
Erratic results	Poor AC ground	Ensure instrument is grounded from case ground to earth ground, call AZI at 1-800-528-7411 or 1-602-470-1414 for assistance.
	Dirt in chamber	Clean unit, See page 51
	Dirt in Pan Support	See page 51 or call AZI at 1-800-528-7411 or 1-602-470-1414 for assistance.
	Pan Support height incorrect	Adjust Pan Support height, see page 12 or call AZI at 1-800-528-7411 or 1-602-470-1414 for assistance.
Display erratic	Unit cold (near freezing)	Allow to warm-up

SYMPTOM	DIAGNOSIS	REMEDY
UNDERLOAD when [START] pressed	Sample pan or pan support not in place	Install pan and/or support, [Quit] test and press [START] again, see page
Instrument won't tare	Test chamber temperature fluctuates/changes	Allow system to stabilize.
	Dirt in test chamber or under pan support	Clean instrument, see page 51 and following

15. SPECIFICATIONS

These specifications are intended as a guide to proper use of the instrument. Specifications and features will vary with application. AZI product specifications are controlled by ISO 9001 procedures and are established and verified during design. They are not to be construed as test criteria for every application. Refer to AZI document Number 4C04-0008 for current specifications controlling this instrument. All specifications and features are subject to change without notice. Periodically contact customer service, 1-800-528-7411 or 1-602-470-1414, to see if any upgrades are available for your instrument.

FEATURE	SPECIFICATION
Dimensions	235 mm H x 300 mm W x 575 mm D (9.5 in H x 12 in W x 24 in D)
Weight	13.9 kg (32 lbs.)
Casework	Per drawing 7200-0244
Power Requirements	110 - 120 volts 50/60 HZ, 1 amp standby, or 8 amps heat on, or 210 - 240 volts 50/60 HZ, 0.5 amp standby, or 4 amps heat on power control and fuses at rear of unit
Heating Range	25 ^o C to 225 ^o C set point in 1 ^o C increments
Test Temperatures	User-set to control Idle, Hi-Start, and Test Temperatures through the heating range.
Balance	Built in, automatic operation
Sample Size	150 milligrams to 40 grams
Resolution	Moisture - 0.01% Balance 0.001 gram
Balance Calibration	Automatic, menu-driven, one-point calibration at 20 grams
Display	30 character, 9 row LCD with back light; text or graphic test display
Test Display	Continuous text of test time, current temperature, programmed test temperature, current sample weight and calculated weight loss.
Interface	RS-232 (9 pin standard) serial port and bi-directional parallel printer port (25 pin standard)
Moisture Range	0.10% to 100% moisture
Firmware	Menu-driven through LCD display
Memory	Storage of last test result and up to five different test parameters plus 2 quality test programs (Weight Test And Tartrate)
Access Code	Two user-selectable codes, up to eight digits in length; One master code and one Calibration code; no limits to access on memory starts; one “universal” code for factory use and override.
Results Display	Moisture, solids, or dry weight

FEATURE	SPECIFICATION
Ending Criteria	Predict, Relaxed, Midrange, and Tight Rate, from 0.01%/minute to 9.99%/minute
Programmable Features	Sample name Lot number or product ID Syringe tare operation for precise test start weights
Certifications	US and Canadian Underwriters Laboratory European Communities, CE Arizona Instrument LLC is an ISO-9001 registered company

16. ACCESSORIES & MAINTENANCE PARTS

CONSUMABLES

800-0037	Sodium Tartrate (500 gram bottle)
990-0003	Filter Paper (100 PCS)
990-0008	Waffle Bottom Sample Pans (100 PCS)
990-0010	Flat Bottom Sample Pans (100 PCS)

SPARE PARTS

170-0014	Fan
190-1001	8 Amp Fuse
190-1002	4 Amp Fuse
200-0002	Power Cord - 110V
200-0003	Power Cord - British Standard - 220V
200-0008	Power Cord - Continental Europe - 220V
200-0021	Optical-switch Cable Assembly
200-0026	RTD Cable Assembly
300-0106	Inside Shroud Gasket
300-0114	Outside Shroud Gasket
355-0079	Gas Spring
600-0152	Pan Support Assembly (Post and Tray Holder)
690-0003	3g Weight
690-0004	5g Weight
690-0007	20g Weight
690-0012	Tweezers
4000-2008	NiCad Batteries
700-0036	MAX 1000 User's Manual
Y990-0129	Pan Support Post Replacement Kit (Post only)

OPTIONS

6000-1044	Null MODEM Cable
Y990-0046	Nitrogen Purge Kit
990-0093	Carrying Case
990-0114	H ₂ S Filter Kit
Y990-0070	Communication Software Kit
Y990-0097	Dust Filter Kit
Y990-0098	Printer Kit, Parallel, 110 V

•

17. WARRANTY

Arizona Instrument LLC warrants the Computrac MAX 1000 to be free from defects in materials or workmanship for two years from the date of purchase for those units sold in the USA. All other sales normally carry a one-year warranty. AZI will repair or replace, at its option, products that AZI determines to be defective during the warranty period. All defective parts replaced by AZI become the property of AZI. Replacement parts are warranted for the remaining portion of the effective warranty period. This warranty does not apply to expendable or maintenance items such as pans and pan supports.

The above warranty does not extend to any product which has been subjected to misuse, abuse, neglect, accident, improper application, modifications or service performed by persons other than AZI's own service representatives; power surges or spikes; negligence in use, maintenance, storage, transportation or handling; or an act of God.

If a MAX product is defective in workmanship or materials, the owner's sole remedy shall be repair or replacement of the defective part, or parts, as provided above. Under no circumstances shall AZI be liable in any way to the owner or any user for any damage including, but not limited to, any loss of business or profits or any other direct, indirect, special incidental, or consequential damages, whether or not foreseeable, and whether or not based on breach of warranty, contract, or negligence in connection with the sale of such products. (Some states do not allow the exclusion or limitation of incidental or consequential damages, so the above limitations or exclusions may not apply to you.)

No other warranty is expressed or implied including the warranties of merchantability or fitness for a particular purpose. In no event shall AZI be liable for consequential and/or incidental damages.

The effective warranty begins on the date of purchase by, or lease to, the first end-user (owner). Keep the dated bill of sale, or invoice, for evidence of the effective warranty date when warranty service is requested.

In the event that any questions or problems should arise in the use or application of your Computrac MAX 1000 unit, call AZI customer service or your technical sales representative at 1-800-528-7411 or 1-602-470-1414.

18. MAINTENANCE CONTRACT

Arizona Instrument LLC has a high level of confidence in the reliability of the MAX. Our sophisticated circuits, advanced design and manufacturing techniques result in a unit that performs reliably over an extended period. To demonstrate our confidence, we offer an extended warranty maintenance contract. For a nominal annual charge, AZI will exchange any subassembly or repair any unit at the factory which fails through no fault of the user. This exchange or repair is on a no-charge basis, except for freight. Contact AZI and ask for the Maintenance Contract Sales Representative.

TRADEMARK AND COPYRIGHT PROTECTION

Copyright 2003, Arizona Instrument LLC All rights reserved.
Computrac™. Computrac, Arizona Instrument, AZI, and the stylized AZI, are registered trademarks of Arizona Instrument LLC.
MAX 1000 is a trademark of Arizona Instrument LLC.
Tygon™ is a registered trademark of the Norton Company.

ARIZONA INSTRUMENT LLC
COMPUTRAC DIVISION

COMPUTRAC MAX 1000 MOISTURE ANALYZER
USER'S MANUAL

If you have any questions regarding the operation of this instrument, please call our toll free number, 1-800-528-7411. Internationally, call 1-602-470-1414 or FAX 1-480-804-0656.

Arizona Instrument LLC
3375 N Delaware St
Chandler, AZ 85225 USA

(602) 470-1414
(800) 528-7411
FAX (480) 804-0656
<http://www.azic.com>
e-mail

azi@azic.com - General
intl@azic.com - International
support@azic.com - Customer Support